



Russian Journal of Veterinary Pathology

Veterinarnaya Patologiya

Peer-reviewed scientific and practical journal

eISSN 2949-4826

Published since 2002

Periodicity – 4 issues per year

DOI: 10.23947/2949-4826



The medal “For Achievements
in the Field of Veterinary Science”
by the Veterinary Medicine
Department of the Russian
Academy of Agricultural Sciences.
Awarded to the editorial board
in 2009.

Founder and Publisher — Don State Technical University (DSTU), Rostov-on-Don, Russian Federation

The “Russian Journal of Veterinary Pathology” is a peer-reviewed scientific and practical journal that publishes the results of the original research and review articles in the field of veterinary medicine. It covers the issues of parasitology, physiology, pharmacology, ecology, and considers the aspects of infectious diseases and other matters of veterinary medicine of companion, farm and wild animals.

The journal aims at enhancing the level of professional knowledge of the target audience and to disseminate worldwide the highly efficient, thoroughly verified scientific research in the field of veterinary medicine using an online open access format for maximum accessibility.

The journal is included in the List of the leading peer-reviewed scientific publications (Higher Attestation Commission under the Ministry of Science and Higher Education of the Russian Federation), where the main scientific results of dissertations for the degrees of Doctor and Candidate of Science in the following scientific specialties should be published.

- Parasitology
- Animal Pathology, Morphology, Physiology, Pharmacology and Toxicology
- Sanitation, Hygiene, Ecology, Veterinary and Sanitary Expertise and Biosafety
- Infectious Diseases and Animal Immunology
- Zootechnics, Feeding, Technologies of Feed Preparation and Livestock Products Production
- Breeding, Selection, Genetics and Animal Biotechnology

<i>Registration</i>	Extract from the Register of Registered Mass Media ЭЛ № ФС 77 – 85552 dated June 27, 2023, issued by the Federal Service for Supervision of Communications, Information Technology and Mass Media
<i>Indexing and Archiving</i>	RISC, DOAJ, AGRIS, CyberLeninka, CrossRef, Internet Archive, Google Scholar
<i>Website</i>	http://www.vetpat.ru/
<i>Address of the Editorial Office</i>	1, Gagarin Sq., Rostov-on-Don 344003, Russian Federation
<i>E-mail</i>	vetpat@donstu.ru
<i>Telephone</i>	+7 (863) 273-85-08
<i>Date of Publication No.1,2026</i>	31.03.2026





ДОНСКОЙ ГОСУДАРСТВЕННЫЙ
ТЕХНИЧЕСКИЙ УНИВЕРСИТЕТ

Ветеринарная патология Russian Journal of Veterinary Pathology

Рецензируемый научно-практический журнал

eISSN 2949-4826

Издается с 2002 года

Периодичность – 4 выпуска в год

DOI: 10.23947/2949-4826



Медаль Отделения ветеринарной
медицины РАСХН
«За достижения в области
ветеринарной науки». Вручена
редакции журнала в 2009 г.

Учредитель и издатель — Федеральное государственное бюджетное образовательное учреждение высшего образования «Донской государственный технический университет» (ДГТУ), г. Ростов-на-Дону

«Ветеринарная патология» — рецензируемый научно-практический журнал, в котором публикуются результаты оригинальных исследований и обзорные статьи в области ветеринарной медицины. Освещаются вопросы паразитологии, физиологии, фармакологии, экологии, уделяется внимание инфекционным болезням и другим аспектам ветеринарии домашних, сельскохозяйственных и диких животных.

Цель журнала заключается в повышении профессионального уровня знаний профильной аудитории и распространении по всему миру высокоэффективных, тщательно проверенных ветеринарных научных исследований, используя только онлайн-формат открытого доступа для максимальной доступности.

Журнал включен в перечень рецензируемых научных изданий, в котором должны быть опубликованы основные научные результаты диссертаций на соискание ученой степени кандидата наук, на соискание ученой степени доктора наук (Перечень ВАК) по следующим научным специальностям:

- 1.5.17 – Паразитология (биологические науки, ветеринарные науки)
- 4.2.1 – Патология животных, морфология, физиология, фармакология и токсикология (биологические науки, ветеринарные науки)
- 4.2.2 – Санитария, гигиена, экология, ветеринарно-санитарная экспертиза и биобезопасность (биологические науки, ветеринарные науки)
- 4.2.3 – Инфекционные болезни и иммунология животных (ветеринарные науки, биологические науки)
- 4.2.4 – Частная зоотехния, кормление, технологии приготовления кормов и производства продукции животноводства (биологические науки, сельскохозяйственные науки)
- 4.2.5 – Разведение, селекция, генетика и биотехнология животных (биологические науки, сельскохозяйственные науки)

<i>Регистрация:</i>	Выписка из реестра зарегистрированных средств массовой информации ЭЛ № ФС 77-85552 от 27.06.2023 г., выдано Федеральной службой по надзору в сфере связи, информационных технологий и массовых коммуникаций
<i>Индексация и архивация:</i>	РИНЦ, DOAJ, AGRIS, CyberLeninka, CrossRef, Internet Archive, Google Scholar
<i>Сайт:</i>	https://www.vetpat.ru/
<i>Адрес редакции:</i>	344003, Российская Федерация, г. Ростов-на-Дону, пл. Гагарина, 1
<i>E-mail:</i>	vetpat@donstu.ru
<i>Телефон:</i>	+7 (863) 273-85-08
<i>Дата выхода №1, 2026 в свет:</i>	31.03.2026



Editorial Board

Editor-in-Chief

Alexey M. Ermakov, Dr.Sci. (Biology), Professor, Don State Technical University (Rostov-on-Don, Russian Federation)

Deputy Chief Editor

Polina V. Aksenova, Dr.Sci. (Biology), Professor, Don State Technical University (Rostov-on-Don, Russian Federation)

Svetoslav D. Todorov, Ph.D, University of São Paulo (São Paulo, Brazil)

Executive Editor

Inna M. Kaloshkina, Cand.Sci. (Veterinary Medicine), Head of the Antiparasitic, Veterinary and Sanitary Activities Department, State-Funded Institution of the Krasnodar Region “Krasnodar Regional Station for Combating Animal Diseases” (Krasnodar, Russian Federation)

Executive Secretary

Alina V. Lamteva, Don State Technical University (Rostov-on-Don, Russian Federation)

Alexander I. Klimentko, Dr.Sci. (Agriculture), Professor, Don State Agrarian University (Persianovsky Settlement, Russian Federation)

Ammar Algburi, Ph.D. (Biology), Dean of the Veterinary Faculty, Diyala University (Baakuba, Iraq)

Anatoly A. Stekolnikov, Dr.Sci. (Veterinary Medicine), Professor, Saint Petersburg State University of Veterinary Medicine (Saint Petersburg, Russian Federation)

Andrey N. Kvochko, Dr.Sci. (Biology), Professor, Stavropol State Agrarian University (Stavropol, Russian Federation)

Anna V. Aleshukina, Dr.Sci. (Medicine), Rostov Scientific Research Institute of Microbiology and Parasitology (Rostov-on-Don, Russian Federation)

Ariunbold Jargalsaikhan, Ph.D., Mongolian State University of Education (Ulaanbaatar, Mongolia)

Fernando Simón Martín, Professor, University of Salamanca (Salamanca, Spain)

Igor V. Bondar, Dr.Sci. (Biology), Head of the Physiology of Sensory Systems Laboratory, Institute of Higher Nervous Activity and Neurophysiology of the Russian Academy of Sciences (Moscow, Russian Federation)

Igor V. Popov, Ph.D (Microbiology), Researcher, Don State Technical University (Rostov-on-Don, Russian Federation)

Jean-François Bruyas, D.V.M, Ph.D., Laureate of the Paul Sabatier University, Diplomate of the European College of Animal Reproduction (ECAR), President of the French Association for the Study of Animal Reproduction, Member of the Exam Committee of the European College of Animal Reproduction (ECAR), Professor of theriogenology, National College of Veterinary Medicine, Food Science and Engineering (Nantes, France)

Koen Venema, Ph.D (Natural Sciences), Maastricht University (Maastricht, Netherlands)

Larisa M Belova, Dr.Sci. (Biology), Professor, Saint Petersburg State University of Veterinary Medicine (Saint Petersburg, Russian Federation)

Larisa F. Sotnikova, Dr.Sci. (Veterinary Medicine), Professor, Russian Biotechnological University (Moscow, Russian Federation)

Marina V. Stepanova, Dr.Sci. (Veterinary Medicine), Associate Professor, Russian Biotechnological University (Moscow, Russian Federation)

Michael L. Chikindas, Cand.Sci. (Biology), Associate Professor of Food Science Department, Rutgers University, the State University of New Jersey (New Brunswick, USA)

Milivoje Urošević, PhD, Full Research Professor, Member of the Veterinary Medicine Academy – Serbian Veterinary Society, Managing Director, Center for Preservation of Indigenous Breeds (9, Vera Dimitrijevic Str. Zemun, Belgrade, 11186, Serbia),

Oleg A. Verkhovsky, Dr.Sci. (Biology), Professor, Diagnostic and Prevention Research Institute for Human and Animal Diseases (Moscow, Russian Federation)

Olga V. Dilekova, Dr.Sci. (Biology), Associate Professor, Stavropol State Agrarian University (Stavropol, Russian Federation)

Onolragchaa Ganbold, Ph.D., Mongolian State University of Education (Ulaanbaatar, Mongolia)

Pavel A. Parshin, Dr.Sci. (Veterinary Medicine), Professor, All-Russian Veterinary Research Institute of Pathology, Pharmacology and Therapy (Voronezh, Russian Federation)

Sergey N. Kartashov, Dr.Sci. (Biology), Professor of the Biology and General Pathology Department, Don State Technical University (Rostov-on-Don, Russian Federation)

Sergey V. Konyaev, Cand.Sci. (Biology), Chief Medical Officer of the Veterinary Clinic “AS Vet” (Novosibirsk, Russian Federation)

Taras I. Aliper, Dr.Sci (Biology), Professor, National Research Center for Epidemiology and Microbiology Named after Honorary Academician N.F. Gamaleya (Moscow, Russian Federation)

Tatyana I. Tverdokhlebova, Dr.Sci. (Medicine), Rostov Scientific Research Institute of Microbiology and Parasitology (Rostov-on-Don, Russian Federation)

Tatyana N. Derezina, Dr.Sci. (Biology), Professor of the Biology and General Pathology Department, Don State Technical University (Rostov-on-Don, Russian Federation)

Vitalii V. Nedosekov, Dr.Sci. (Veterinary Medicine), Professor of the Institute of Veterinary Medicine, National Agrarian University (Kiev, Ukraine)

Vladimir A. Chistyakov, Dr.Sci. (Biology), Academy of Biology and Biotechnology of Southern Federal University, (Rostov-on-Don, Russian Federation)

Vladimir V. Makarov, Dr.Sci. (Biology), Professor, Honoured Scholar of the Russian Federation, Professor, Peoples’ Friendship University of Russia (Moscow, Russian Federation)

Yurii A. Vatnikov, Dr.Sci. (Veterinary Medicine), Professor, Peoples’ Friendship University of Russia (Moscow, Russian Federation)

Редакционная коллегия

Главный редактор

Ермаков Алексей Михайлович, доктор биологических наук, профессор, Донской государственной технической университет (Ростов-на-Дону, Российская Федерация)

Заместитель главного редактора

Аксенова Полина Владимировна, доктор биологических наук, профессор, Донской государственной технической университет (Ростов-на-Дону, Российская Федерация)

Тодоров Святослав Димитров, Ph.D, Университет Сан-Паулу (Сан-Паулу, Бразилия)

Выпускающий редактор

Калошкина Инна Муратовна, кандидат ветеринарных наук, начальник отдела противопаразитарных, ветеринарно-санитарных мероприятий ГКУ КСББЖ «Краснодарская» (Краснодар, Российская Федерация)

Ответственный секретарь

Ламтева Алина Владимировна, Донской государственной технической университет (Ростов-на-Дону, Российская Федерация)

Алипер Тарас Иванович, доктор биологических наук, профессор, Федеральный научно-исследовательский центр эпидемиологии и микробиологии им. почетного академика Н.Ф. Гамален (Москва, Российская Федерация)

Аммар Альгбури, Ph.D (биология), декан ветеринарного факультета, Университет Дияла (Баакуба, Ирак)

Алешукина Анна Валентиновна, доктор медицинских наук, Ростовский научно-исследовательский институт микробиологии и паразитологии (Ростов-на-Дону, Российская Федерация)

Ариунболд Жаргалсайхан, Ph.D, Монгольский государственный университет образования (Улан-Батор, Монголия)

Белова Лариса Михаловна, доктор биологических наук, профессор, Санкт-Петербургский государственный университет ветеринарной медицины (Санкт-Петербург, Российская Федерация)

Бондарь Игорь Вечеславович, доктор биологических наук, Заведующий лабораторией физиологии сенсорных систем, Институт высшей нервной деятельности и нейрофизиологии РАН (Москва, Российская Федерация)

Брюя Жан-Франсуа, DVM, Ph.D, лауреат Университета Поля Сабатье, дипломант Европейского колледжа репродукции животных (ECAR), президент Французской ассоциации по изучению репродукции животных, член экзаменационной комиссии Европейского колледжа репродукции животных (ECAR), профессор териогенологии Национального колледжа ветеринарной медицины, пищевых наук и инженерии (Нант, Франция)

Ватников Юрий Анатольевич, доктор ветеринарных наук, профессор, Российский университет дружбы народов (Москва, Российская Федерация)

Верховский Олег Анатольевич, доктор биологических наук, профессор, Научно-исследовательский институт диагностики и профилактики болезней человека и животных (Москва, Российская Федерация)

Дерезина Татьяна Николаевна, доктор биологических наук, профессор, Донской государственной технической университет (Ростов-на-Дону, Российская Федерация)

Дилекова Ольга Владимировна, доктор биологических наук, доцент, Ставропольский государственный аграрный университет (Ставрополь, Российская Федерация)

Карташов Сергей Николаевич, доктор биологических наук, Донской государственной технической университет (Ростов-на-Дону, Российская Федерация)

Квачко Андрей Николаевич, доктор биологических наук, профессор, Ставропольский государственный аграрный университет (Ставрополь, Российская Федерация)

Клименко Александр Иванович, доктор сельскохозяйственных наук, профессор, Донской государственной аграрный университет (пос. Персиановский, Ростовская область, Российская Федерация)

Коняев Сергей Владимирович, кандидат биологических наук, главный врач ветеринарной клиники «АС Вет» (Новосибирск, Российская Федерация)

Кун Венема, Ph.D (естественные науки), профессор, Маастрихтский университет (Маастрихт, Нидерланды);

Макаров Владимир Владимирович, доктор биологических наук, профессор, Российский университет дружбы народов (Москва, Российская Федерация)

Недосеков Виталий Владимирович, доктор ветеринарных наук, профессор, Институт ветеринарной медицины Национального аграрного университета (Киев, Украина)

Онолрагчаа Ганболд, Ph.D, Монгольский государственный университет образования (Улан-Батор, Монголия)

Паршин Павел Андреевич, доктор ветеринарных наук, профессор, Всероссийский научно-исследовательский ветеринарный институт патологии, фармакологии и терапии (Воронеж, Российская Федерация)

Попов Игорь Витальевич, Ph.D (микробиология), научный сотрудник, Донской государственной технической университет (Ростов-на-Дону, Российская Федерация)

Сотникова Лариса Федоровна, доктор ветеринарных наук, профессор, Российский биотехнологический университет (Москва, Российская Федерация)

Стекольников Анатолий Александрович, доктор ветеринарных наук, профессор, ректор, Санкт-Петербургский государственный университет ветеринарной медицины (Санкт-Петербург, Российская Федерация)

Степанова Марина Вячеславовна, доктор ветеринарных наук, доцент, Российский биотехнологический университет (Москва, Российская Федерация)

Твердохлебова Татьяна Ивановна, доктор медицинских наук, Ростовский научно-исследовательский институт микробиологии и паразитологии (Ростов-на-Дону, Российская Федерация)

Фернандо Саймон Мартин, профессор Университета Саламанки (Саламанка, Испания)

Чикиндас Михаил Леонидович, кандидат биологических наук, доцент, Рутгерский государственный университет штата Нью-Джерси (Нью-Брансуик, США)

Чистяков Владимир Анатольевич, доктор биологических наук, Академия биологии и биотехнологии, Южный федеральный университет (Ростов-на-Дону, Российская Федерация)

Урошевич Миливое, доктор сельскохозяйственных наук, профессор, член Академии ветеринарной медицины – Сербского ветеринарного общества, директор по научной работе, Центр сохранения аборигенных пород (Белград, Сербия)

Contents

PARASITOLOGY

Prevalence of Trematodes of the Family Notocotylidae in the Perm Territory

Tatiana N. Sivkova, Darya A. Lokteva, Margarita V. Khazova 7

The Small Pond Snail (*Lymnaea truncatula*) and Its Role in Spreading Trematodiasis. The Situation in the Kaluga Region: Literature Review

Yaroslav S. Morozov, Anna M. Nikanorova 17

ANIMAL PATHOLOGY, MORPHOLOGY, PHYSIOLOGY, PHARMACOLOGY AND TOXICOLOGY

Development of an Intelligent System for Diagnosing Rumen Acidosis in Cows. Part 2: Computer Implementation

Vladimir V. Pobedinskiy, Andrey A. Pobedinskiy, Grigory A. Iovlev 26

A Clinical Case of Proliferative and Necrotizing Otitis Externa (PNOE) in an Elderly Cat

Anastasia Yu. Kochetkova, Anna S. Fomina 34

ANIMAL BREEDING, SELECTION, GENETICS, AND BIOTECHNOLOGY

Basic Principles and Practical Instructions for Proper Feeding of Donkeys

Maksim V. Bytov, Vladlena D. Zubareva, Alexander S. Krasnoperov, Natalia A. Bezborodova, Marina A. Pechenkina, Olga V. Sokolova 41

SANITARY, HYGIENIC, ECOLOGICAL, VETERINARY-SANITARY EXAMINATION AND BIOLOGICAL SAFETY

Uncontrollable Mortality in Agricultural Animals in the Russian Federation: A State-Level Problem in the Context of Sanction Restrictions

Elena O. Mirgorodskaya, Yulia L. Stepanova, Igor O. Potapenko, Alexey M. Ermakov 50

Содержание

ПАРАЗИТОЛОГИЯ

Распространенность трематод семейства *Notocotylidae* на территории Пермского края

Т.Н. Сивкова, Д.А. Локтева, М.В. Хазова 7

Малый прудовик (*Lymnaea truncatula*) и его роль в распространении трематодозов. Ситуация в Калужской области. Обзор научной литературы

Я.С. Морозов, А.М. Никанорова 17

ПАТОЛОГИЯ ЖИВОТНЫХ, МОРФОЛОГИЯ, ФИЗИОЛОГИЯ, ФАРМАКОЛОГИЯ И ТОКСИКОЛОГИЯ

Создание интеллектуальной системы диагностирования ацидоза рубца у коров. Часть 2: Компьютерная реализация.

В.В. Побединский, А.А. Побединский, Г.А. Иовлев 26

Клинический случай пролиферативного и некротизирующего наружного отита (PNOE) у возрастной кошки

А.Ю. Кочеткова, А.С. Фомина 34

РАЗВЕДЕНИЕ, СЕЛЕКЦИЯ, ГЕНЕТИКА И БИОТЕХНОЛОГИЯ ЖИВОТНЫХ

Поиск ассоциаций однонуклеотидных полиморфизмов с показателями экстерьера (газовые параметры) коров голштинской породы

М.В. Бытов, В.Д. Зубарева, А.С. Краснощёров, Н.А. Безбородова, М.А. Печёнкина, О.В. Соколова 41

САНИТАРИЯ, ГИГИЕНА, ЭКОЛОГИЯ, ВЕТЕРИНАРНО-САНИТАРНАЯ ЭКСПЕРТИЗА И БИОБЕЗОПАСНОСТЬ

Неконтролируемый падеж сельскохозяйственных животных в Российской Федерации: государственная проблематика в условиях санкционных ограничений

Е.О. Миргородская, Ю.Л. Степанова, И.О. Потапенко, А.М. Ермаков 50

PARASITOLOGY

ПАРАЗИТОЛОГИЯ



UDC 619:616.995.122

<https://doi.org/10.23947/2949-4826-2026-25-1-7-16>

Original Empirical Research

Prevalence of Trematodes of the Family Notocotylidae in the Perm Territory

 Tatiana N. Sivkova , Darya A. Lokteva , Margarita V. Khazova 

Perm State Agro-Technological University Named after Academician D.N. Pryanishnikov, Perm, Russian Federation

 ✉ tatiana-sivkova@yandex.ru

EDN: LKXCIS

Abstract

Introduction. Notocotylidoses are fairly widespread in Russia dioxenous trematode diseases of birds and some mammals caused by the members of the family Notocotylidae, which parasitize in the intestines. Although the Perm Territory conditions (hydrological situation, prevalence of susceptible hosts) are apt to the increase of the population of this trematode species, the epizootic situation for this trematode in the region remains unstudied. The aim of the article is to investigate the prevalence of trematodes of the family Notocotylidae in the Perm Territory.

Materials and Methods. The objects of the study were freshwater gastropods (n=340), cadavers of wild waterfowl (n=16) and samples of mallards' droppings from the places of their aggregations (n=139) collected in the Perm Territory during the warm seasons of 2024 and 2025. The research was carried out at Perm State Agro-Technological University named after Academician D.N. Pryanishnikov in compliance with the standard techniques: using microscopy compressor; partial helminthological dissections; sequential washings of droppings; standard histological examination of tissues of infested mollusks and ducks.

Results. A single *Anisus vortex* specimen from the Motovilikha Pond (Perm) was found to be infested with cercaria of *Notocotylus sp.* Also, marita of *N. attenuatus* was found in the intestines of a *Clangula hyemalis*. In the histological samples of the infested mollusk, edema, friable tissues, mucin hypersecretion were revealed, and single cercariae were isolated. Also, the exposure of bird's intestines to *N. attenuatus* resulted in chronic condition manifested in edema and degenerative changes in the tissues, as well as the development of the macrophage response in the lymph nodes.

Discussion and Conclusion. The presence of larval notocotylids in the Perm Territory did not confirm having a natural focus of avian notocotylidosis there. In this case, mammals are likely to be the definitive hosts. Marita of *N. attenuatus* was detected in a migratory species, in the long-tailed duck, which might have been infested in its wintering or nesting areas.

Keywords: notocotylids, Notocotylidae, trematodes, prevalence, birds, mollusks, histological changes, Perm Territory

For Citation. Sivkova TN, Lokteva DA, Khazova MV. Prevalence of Trematodes of the Family Notocotylidae in the Perm Territory. *Russian Journal of Veterinary Pathology*. 2026;25(1):7–16. <https://doi.org/10.23947/2949-4826-2026-25-1-7-16>

Оригинальное эмпирическое исследование

Распространенность трематод семейства Notocotylidae на территории Пермского края

 Т.Н. Сивкова , Д.А. Локтева , М.В. Хазова 

Пермский государственный аграрно-технологический университет имени академика Д.Н. Прянишникова, г. Пермь, Российская Федерация

 ✉ tatiana-sivkova@yandex.ru

Аннотация

Введение. Нотокотилидозы — довольно распространенные в России диксенные трематодозы птиц и некоторых млекопитающих, вызываемые представителями семейства Notocotylidae, паразитирующими в кишечнике. Несмотря на присутствующие в Пермском крае благоприятные факторы роста численности этого вида трематод

(гидрология, распространенность восприимчивых хозяев), эпизоотическая ситуация по ним в регионе на данный момент остается неизученной. Цель статьи — исследовать распространенность трематод семейства Notocotylidae на территории Пермского края.

Материалы и методы. Объектом исследования стали пресноводные брюхоногие моллюски (n=340), трупы диких водоплавающих птиц (n=16) и пробы помёта из мест скопления крякв (n=139), собранные на территории Пермского края в теплый сезон 2024 и 2025 гг. Исследования осуществлялись в ПГАТУ имени Д.Н. Прянишникова согласно общепринятым методикам: компрессорная микроскопия; метод неполных гельминтологических вскрытий; последовательные промывания помёта; стандартное гистологическое исследование тканей инвазированных моллюсков и утиных.

Результаты исследования. Выявлена инвазия церкариями *Notocotylus sp.* одного экземпляра *Anisus vortex* из Мотовилихинского пруда (г. Пермь), а также марита *N. attenuatus* в кишечнике у *Clangula hyemalis*. Гистологические препараты инвазированного моллюска показали отёчность, разволокнение тканей, гиперсекрецию муцина, также выявлены отдельные церкарии. Воздействие *N. attenuatus* на кишечник птицы также оказалось хроническим и проявилось отёком и дистрофическими изменениями в тканях, развитием макрофагальной реакции в лимфатических узлах.

Обсуждение и заключение. Наличие личинок нотокотилид на территории Пермского края не подтвердило природный очаг нотокотилидоза птиц. Вероятно, дефинитивным хозяином в данном случае выступают млекопитающие. Марита *N. attenuatus* выявлена у пролетного вида — морянки, которая могла быть инвазирована в местах зимовки или гнездования.

Ключевые слова: нотокотилиды, Notocotylidae, трематоды, распространенность, птицы, моллюски, гистологические изменения, Пермский край

Для цитирования. Сивкова Т.Н., Локтева Д.А., Хазова М.В. Распространенность трематод семейства Notocotylidae на территории Пермского края. *Ветеринарная патология.* 2026;25(1):7–16. <https://doi.org/10.23947/2949-4826-2026-25-1-7-16>

Introduction. According to the modern understanding, trematodes are parasitic organisms that had appeared in the Cambrian period and currently consist of more than 2 700 nominal genera and approximately 18 000 species [1] and parasitize in fish, amphibians, reptiles, birds, mammals, and humans. Most of them are characterised by dioxenous or trioxenous life cycles, and involve gastropods as intermediate hosts. Many of them are the causative agents of diseases in agricultural and domestic animals, as well as in humans, and, therefore, are being actively and comprehensively studied. Particular attention is usually paid to such diseases as opisthorchiasis, fascioliasis, clonorchiasis, paragonimiasis, schistosomiasis, etc., however, some infestations remain insufficiently studied.

One of such poorly studied infestations are notocotylidoses — the trematodiasis in animals caused by parasitism of the representatives of the family Notocotylidae, which are registered in the intestines of many bird species, as well as in some mammals [2–6]. From the economic point of view, notocotylidoses cause significant damage to poultry reared at the farms and to some species of game birds. Parasitic worms cause mechanical damage to the intestinal mucosa and facilitate penetration of microorgan-

isms into the intestinal wall. Despite the fact that the morphology, life cycles and molecular analysis of notocotylids attract the attention of specialists of the relevant fields [7, 8], pathoanatomical changes caused by Notocotylidae are poorly described. The Manual on Veterinary Parasitology specifies that in trematodiasis cause the catarrhal or catarrhal-hemorrhagic inflammation of the cecum and rectum mucous membrane; at the sites of parasite attachment, the epithelium is destroyed and ulcers appear; in the infested mollusks, the reaction is formed in response to the invasion and development of trematode larval stages [9]. However, no likewise information could be found in the literature with regard to infestation by the representatives of the family Notocotylidae.

Notocotylidoses had been widely spread in Russia since long ago. In earlier publications, the infestations were reported to be revealed in Western Siberia [10], in the Caucasus [11], in the European North of the country [2, 12] and in some other regions. In the Perm Territory, there are more than 29 000 rivers with a total length of about 90 000 km, about 115 lakes (with an area of more than 10 hectares), 18 reservoirs, including the large ones such as Kama and Votkinsk reservoirs, and numerous ponds¹. The malacofauna in the Upper and Middle Kama

¹ According to the Data of the Ministry of Natural Resources and Environment of the Russian Federation (Perm Territory). <https://priroda.permkrai.ru/?ysclid=mmoxx4z0we339984914> (accessed: 5.11.2025)

basin alone includes 97 species of 30 genera and 10 families of the classes Bivalvia and Gastropoda. The most diverse are the families Sphaeriidae (29 species), Lymnaeidae and Planorbidae (21 species each) [13]. The avifauna of the region is also rich [14, 15]: according to official data of the Ministry of Natural Resources and Environment for 2024, there were 71 846 ducks and 4 665 geese registered in the Perm Territory².

Despite the abundance of water resources, wide spreading of specific hosts, and possibility of infestation to circulate in natural foci, no targeted study of the prevalence of notocotylidoses in the Perm Territory has been conducted, which served the rationale for the present work.

Materials and Methods. The research was conducted at the Department of Infectious Diseases of Perm State Agro-Technological University named after Academician D.N. Pryanishnikov. Due to the notocotylids' having dixenous life cycle, the following materials were taken for the study: freshwater mollusks (n=340); cadavers of wild waterfowl that died for various reasons (n=16); droppings samples (n=139) collected in mallard aggregation areas. 39 locations of various water bodies in several districts of Perm Territory and the city of Perm were explored during the warm seasons of 2024 and 2025 to collect the material: Raiskii sad (Motovilikha Pond), Danilikha River, Zoloty Peski, Parkovyi and Lipovaya gora districts. All locations are characterized by free access to water and abundant fauna and flora. Mollusks were collected manually, and their species membership was determined by the authors themselves based on conchological features using open-access species identification key [16–18]. Shell height and width, and shell mouth width were measured using a TOPEX callipers (Poland). Compressor microscopy was then performed using a MIS-7 compressor ("Petrolazer", Russia) and a Mikromed MS-1 stereomicroscope ("Micromed", Russia). The shells were additionally examined with a binocular magnifying glass to detect larval forms of trematodes.

Until being provided to ornithologists for autopsy, the wild duck cadavers were stored at –18°C. Autopsy was performed according to the standard technique.

The locations of collecting the material and amounts of material collected for examination are presented in Table 1.

For histological examination, mollusk tissues were placed in the formalin solution with 4% formaldehyde con-

tent; birds' autopsy specimens were placed in the 10% formaldehyde solution. Hematoxylin-eosin-stained specimens were scanned and viewed using the Vision Assist automated system (West Medica, Austria) and Vision microscopy automation software ("Medica Product", Russia).

Droppings samples were analysed using sequential washing technique. Helminth eggs were identified by morphological characteristics [19].

Research Results. The study of 15 specimens of Whirlpool ramshorn snail (*Anisus vortex*) from the Motovilikha Pond (Perm), collected in the first ten days of June, resulted in detecting the cercariae with the morphological characteristics of *Notocotylus sp.* in one of the cases (Fig. 1). The infestation extensity (IE) in Planorbidae from the Motovilikha Pond was 6.67%. The distribution of *A. vortex* from the Motovilikha Pond by shell size, taking into account their infestation, is presented in Fig. 2.

Histological examination of the infested mollusk revealed that the tissue between the mantle and muscular layer was frayed and edematous, with a high concentration of mucin in the cell cytoplasm. In the walls of capsules consisting of a series of cells, single cercariae were found, which had a visible pigmented outer layer and underlying bundles of muscle fibers, as well as parenchyma and tubular structures located closer to the tail and representing the digestive system organs (Fig. 3). In the tissues surrounding the parasites no inflammatory reaction was observed.

Of 16 duck specimens, only the intestines of the long-tailed duck — a rarely found in the Perm Territory northern migratory marine species that winters on the shores of the Black and Azov Seas — was found to be infested with *N. attenuates* (Fig. 4). The examination revealed the thickened intestinal wall, mucous membrane of grey colour, abundantly covered with thick non-transparent mucus and grey-yellow creamy substance. Helminths were found in the mucus. Histological examination carried out with preservation of intestinal wall structure, the villi, and the crypts, revealed the dystrophic changes in the epithelial cells. Dystrophic processes were also observed in the intermuscular ganglia. A moderate macrophage response was observed in the medulla of the lymph nodes. The pronounced edematization of submucosa was observed (Fig. 5). The above changes describe the chronic toxic effect of *N. attenuates* at the place of its localization.

² According to the Data of the Ministry of Natural Resources and Environment of the Russian Federation (Perm Territory). <https://priroda.permkrai.ru/deyatelnost/okhotnichi-turizm/okhotnichi-resursy-i-okhotnichiturizm> (accessed: 5.11.2025)

Material for parasitological examination and the locations of its collection

No.	Species	Habitat	Number of specimens, pcs.
Mollusks			
Viviparidae			
1	Common river snail <i>Viviparus viviparus</i>	Kama Reservoir (Perm; Berezniki Municipality; Dobryansky District)	14
		Sylva River (Kungur District)	16
		Chusovaya River (Perm)	10
		Suzdalka River (Krasnokamsk)	1
		Mulyanka River (Perm)	1
		Lipogorsky pond (Perm)	9
Lymnaeidae			
2	Oval pond snail <i>Lymnaea ovata</i>	Usva River (Gubakhinsky District)	51
		Poludenka River (Gornozavodsky District)	3
		Koiva River (Gornozavodsky District)	1
		Kopanets River (Osinsky District)	19
		Sherya River (Nytvinsky District)	2
		Syuzva River (Krasnokamsk District)	4
		Mulyanka River (Perm)	2
		Sylva River (Kishertsky District)	1
		Maysky Pond (Krasnokamsk District)	2
		Lipogorsky pond (Perm)	4
3	Fragile pond snail <i>Lymnaea fragilis</i>	Maysky Pond (Krasnokamsk District)	13
		Koiva River (Gornozavodsky District)	5
		Sherya River (Nytvinsky District)	3
		Sylva River (Kungur District)	2
4	Great pond snail <i>Lymnaea stagnalis</i>	Suzdalka River (Krasnokamsk)	3
		Reservoirs (Krasnokamsky District: settlements Konets-Bor, Busyryata, Khukhryata, Abakshata, and Horticultural Non-Profit Partnership Syuzva-5)	65
		Kopanets River (Osinsky District)	5
		Sylva River (Perm District)	3
		Reservoir (Perm District, Horticultural Non-Profit Partnership Rodnik)	1
5	Wandering pond snail <i>Lymnaea peregra</i>	Cut-off Lake (Krasnokamsk District)	15
6	Marsh pond snail <i>Stagnicola palustris</i>	Suzdalka River (Krasnokamsk)	4
		Cut-off Lake (Krasnokamsk District)	16
7	<i>Stagnicola callomphala</i>	Syuzva River (Krasnokamsk District)	6
		Lasva River (Krasnokamsk Region)	3
8	Ear pond snail <i>Radix auricularia</i>	Suzdalka River (Krasnokamsk)	3
		Syuzva River (Krasnokamsk District)	3
		Poludenka River (Gornozavodsky District)	2
Planorbidae			
9	Whirlpool ramshorn snail <i>Anisus vortex</i>	Motovilikha Pond (Perm)	15
10	Great ramshorn snail <i>Planorbarius corneus</i>	Sherya River (Nytvinsky District)	2
		Lipogorsky Pond (Perm)	2
11	Margined ramshorn snail <i>Planorbis planorbis</i>	Kopanets River (Osinsky District)	2
		Motovilikha Pond (Perm)	5
12	<i>Planorbidae spp.</i>	Cut-off Lakes (Krasnokamsk District)	19
		Kama Reservoir (Perm)	3
Birds			
13	Mallard <i>Anas platyrhynchos</i>	Perm; Perm District; Chusovskoy District	6
14	Tufted duck <i>Aythya fuligula</i>	Perm Territory	4
15	Garganey <i>Spatula querquedula</i>	Krasnokamsk District.	2
16	Eurasian teal <i>Anas crecca</i>	Perm Territory	1
17	Long-tailed duck <i>Clangula hyemalis</i>	Mys Settlement (Chusovskoy District)	1
18	Common merganser <i>Mergus merganser</i>	Mys Settlement (Chusovskoy District)	2



Fig. 1. Cercaria of *Notocotylus sp.* found in *Anisus vortex*. Magnification $\times 400$.

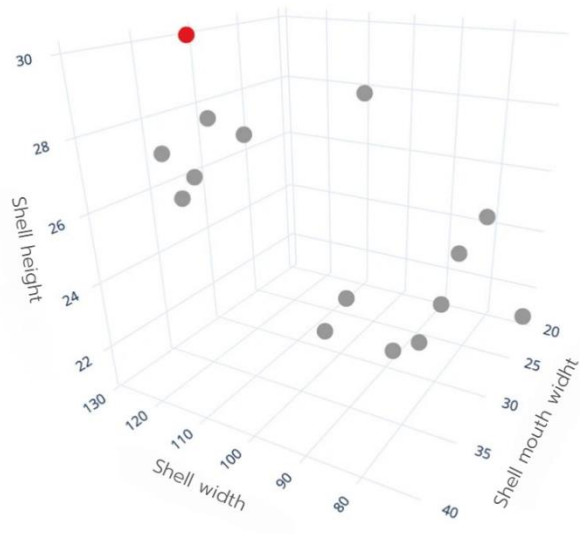

Fig. 2. Distribution of *Anisus vortex* by size, taking into account infestation (gray dots – not infested, red — infested)

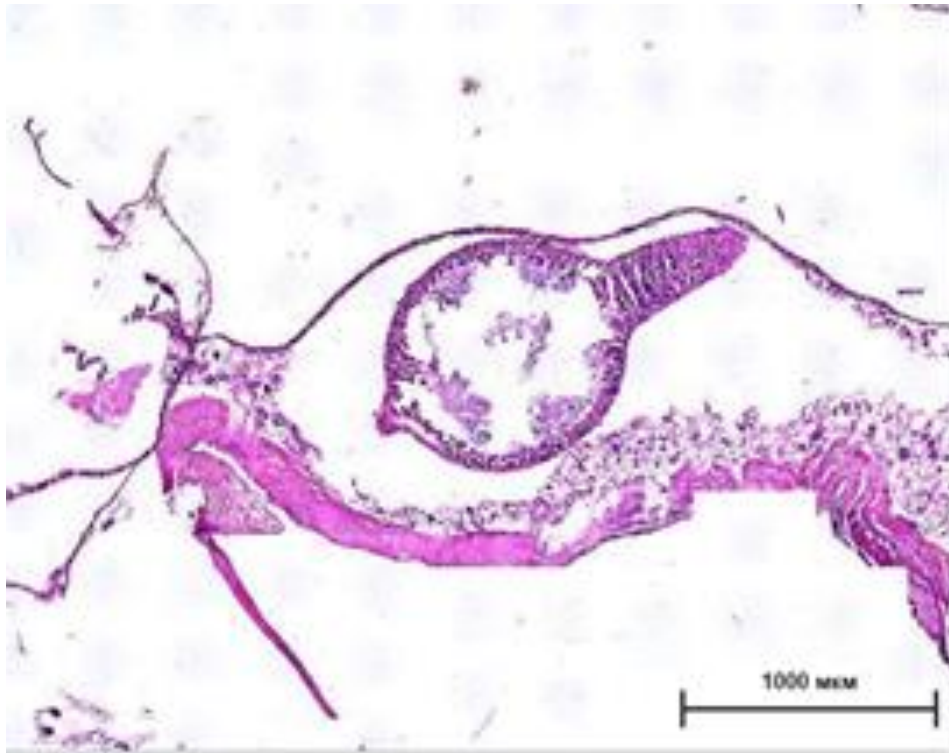

Fig. 3. *Anisus vortex* tissues infested with cercariae of *Notocotylus sp.* Magnification $\times 100$



Fig. 4. Marita of *N. attenuatus* found in the intestines of a long-tailed duck.
Magnification $\times 100$

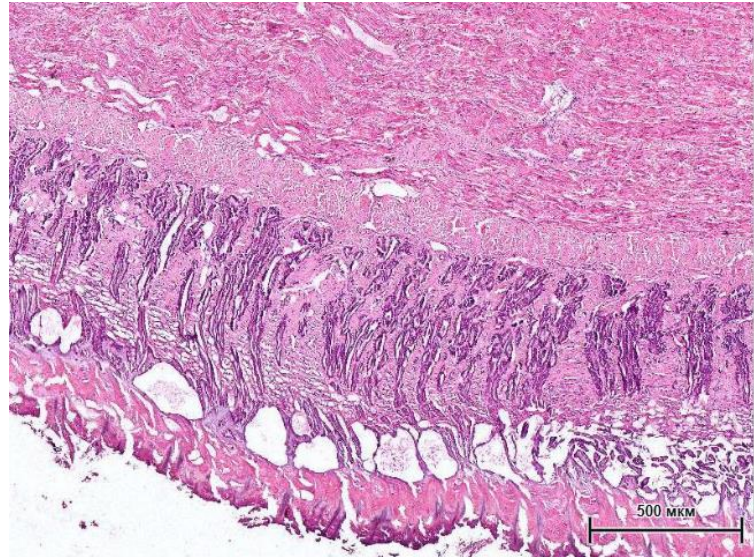

Fig. 5. Long-tailed duck intestines infested with *N. attenuatus*.
Magnification $\times 200$

Thus, the examination of freshwater mollusks in the Perm Territory resulted in acknowledging the presence of parthenites of notocotylids only in the Motovilikha Pond. Whereas, the examination of faeces of ducks from this location, had revealed no eggs characteristic for *N. attenuatus* in any of the cases, even though the concentration of mallards in this pond was significant, and the number of droppings samples examined at different time of the year equalled 53. The discovery of *N. attenuatus* in a single migratory duck is likely to indicate its infestation in nesting or wintering areas.

Discussion and Conclusion. Analysis of shell size features, made it possible to divide the sample into two groups: one group — represented by the larger and older specimens ($n=7$), which included a specimen infested with notocotylids; the second group ($n=8$) consisted of younger and smaller specimens. No information concerning the age of mollusks susceptible to infestation by notocotylids could be found in the scientific literature; however, it is acknowledged that Bithyniidae become in maximum infested with trematodes at the age of 2–3 years, and the timeline of infestation largely depends on the ambient temperature [17, 18].

Compared to similar indicators in other regions, the IE in mollusks of the family Bithyniidae in the estuary of the Kargat River (Western Siberia) during many years of observation was only 0.62%, with notocotylids being completely absent in the sample of mollusks in some of the

years. The level of infestation with parthenites of notocotylids in mollusks of the family Lymnaeidae fluctuated between 0.1 and 0.2% [10]. In our sample, Lymnaeidae were not infested by notocotylids in any of the cases. As to Bithyniidae, they were not found in any of the locations.

According to the scientific data, mallards, garganeys, shovellers, gadwalls, common pochard, and other anseriformes are often infested by notocotylids with the Infestation Intensity (II) of up to 1118 specimens [10, 21]; infestation with notocotylids is also found in many wild species worldwide [22–24]. Notocotylids are also known to parasitize not only in waterfowl, but in some micromammals too [5]. Thus, the Palearctic species *N. noyeri* had been recorded in 38.46% of voles of the species *Microtus oeconomus* near the Makhnevskaya cave (Aleksandrovsky District, Perm Territory) [26]. It could be assumed that the cercariae found in the ramshorn snails belong to notocotylids hosted by micromammals, although according to some data, some of the notocotylids, can be hosted both by birds and rodents [27].

The Motovilikha Pond is an artificial reservoir (Figs. 6–7) having the area of 0.8–0.9 km², created in 1736–1738 to serve the needs of the Motovilikha copper smelting plant. Since 1991, it got the status of a specially protected natural area of regional importance. Currently, its banks are primarily occupied by private low-rise buildings, as well as recreational areas where micromammals apparently find suitable habitat.

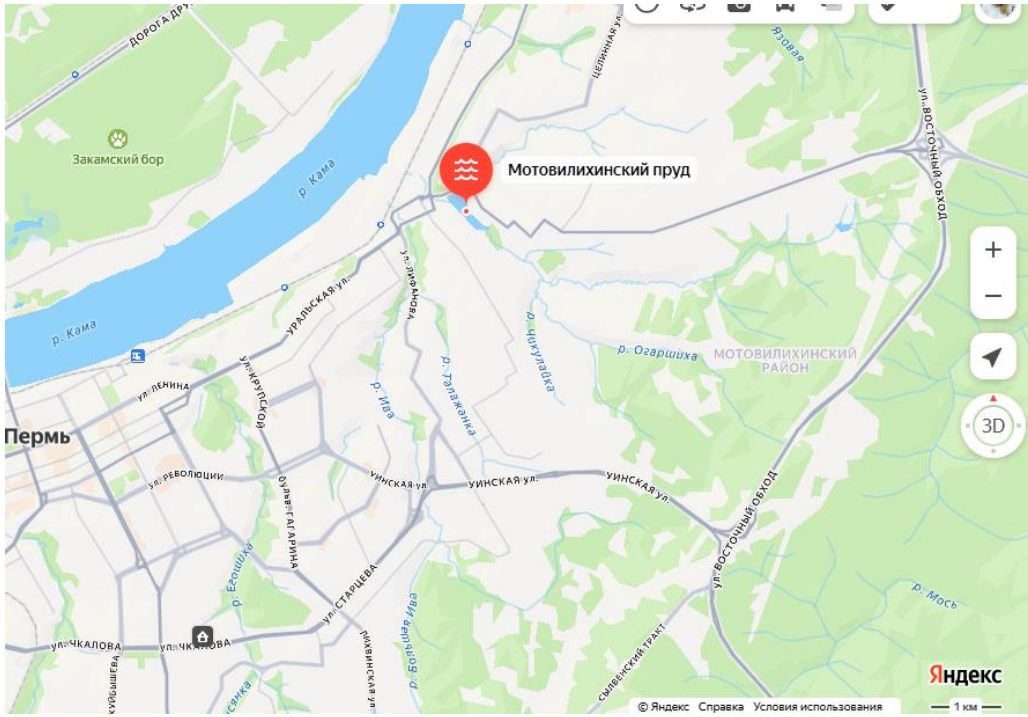

Fig. 6. Geographical location of the Motovilikha Pond in Perm



Fig. 7. Location of collecting the mollusks in the coastal area of the Motovilikha Pond

The study conducted in Perm and the Perm Territory has revealed the infestation of the mollusks of the family Planorbidae with invasive forms of notocotylids, which were not detected in the faeces of ducks from the same location. *N. attenuatus* was recorded to

parasitize only in the long-tailed duck, which is a migratory species. Therefore, a conclusion about the absence of the natural foci of notocotylidosis in birds in the studied territory can be made.

References

- Gibson DI, Jones A, Bray RA (Eds.). *Keys to the Trematoda. Volume 2*. Wallingford, UK: CABI Publishing; 2005. 768 p.
- Gonchar AG. *Life Cycles of Trematodes of the Family Notocotylidae in Ecosystems of the Northern Seas' Coasts*. Extended Abstract of Cand.Sci. (Biology) Dissertation. Saint Petersburg; 2023. 25 p. (In Russ.)
- Aguilar-Morales A, Sánchez-Nava P, Aguilar Ortigoza CJ, Rodríguez-Romero F. Variaciones Morfométricas del Género *Notocotylus* (Digenea: Notocotylidae), Parásitos de Avesacuáticas (Rallidae y Anatidae) en las Ciénegas de Lerma, Estado de México. *Acta Zoológica Mexicana*. 2022;38:1–16. <https://doi.org/10.21829/azm.2022.3812402>
- Buriro SA, Birmani NA. Morphological Study of *Notocotylus Jamshorensis* n. sp. (Trematoda: Notocotylidae) from Mallard *Anas Platyrhynchos* of Hamal Lake of Pakistan. *The Research of Medical Science Review*. 2024;2(3):2087–2093. <https://doi.org/10.5281/zenodo.14733255>
- Gagnon DK, Kasl EL, Preisser WC, Belden LK, Detwiler JT. Morphological and Molecular Characterization of *Quinqueserialis* (Digenea: Notocotylidae) Species Diversity in North America. *Parasitology*. 2021;148(9):1083–1091. <https://doi.org/10.1017/S0031182021000792>
- Flores VR, Hernández-Orts JS, Viozzi GP. A New Species of *Notocotylus* (Digenea: Notocotylidae) from the Black-Necked Swan *Cygnus Melancorhyphus* (Molina) of Argentina. *Veterinary Parasitology: Regional Studies and Reports*. 2023;45:100925. <https://doi.org/10.1016/j.vprsr.2023.100925>
- Flores V, Brugni N. *Notocotylus Biomphalariae* n. sp. (Digenea: Notocotylidae) from *Biomphalaria Peregrina* (Gastropoda: Pulmonata) in Patagonia, Argentina. *Systematic Parasitology*. 2005;61(3):207–14. <https://doi.org/10.1007/s11230-005-3166-2>
- Gonchar A, Jouet D, Skirnisson K, Krupenko D, Galaktionov K. Transatlantic Discovery of *Notocotylus Atlanticus* (Digenea: Notocotylidae) Based on Life Cycle Data. *Parasitology Research*. 2019;118:1445–1456. <https://doi.org/10.1007/s00436-019-06297-8>
- Galat VF, Yatusевич AI (Eds.) Notocotylidosis in Birds. In book: *Manual on Veterinary Parasitology*. Minsk: Information and Data Center of the Ministry of Finance; 2015. 496 p. (In Russ.) URL: <https://www.activestudy.info/nokotilidozypic/?ysclid=mh8xqzwfzg209359300> (accessed: 28.10.2025)
- Serbina EA, Bonina OM. Dynamics of Foci of Bird Notocotylidosis in the Ecosystem of Lake Chany (Western Siberia) in the Last 80 Years. *Russian Journal of Parasitology*. 2015;3:29–36. (In Russ.)
- Kodzokova EK. *Ecological and Epizootiological Assessment of Notocotylidosis in Waterfowl in the Central Caucasus Region and Development of Methods for Regulating the Number of Trematodes*: Extended Abstract of Cand.Sci. (Biology) Dissertation. Makhachkala; 2004. 25 p. (In Russ.)
- Yakovleva GA., Lebedeva D.A., Ieshko E.P. Trematodes in Wetland Birds of Karelia (Based on Materials from the 319th USSR Helminthological Expedition, 1958–1962). *Trudy Karelskogo nauchnogo tsentra RAN (Proceedings of the Karelian Research Center of the Russian Academy of Sciences)*. 2015;2:95–110. (In Russ.)
- Ovchankova NB. Taxonomic Structure and Origin of Malacofauna in River Basins of the East European Plain and the Urals. In: *Proceedings of the XI All-Russian Congress of Young Researchers in Biological Sciences with the International participation "Symbiosis—Russia 2019" (Perm, May 13–15, 2019)*. Perm: Perm State National Research University; 2019. P. 188–190. (In Russ.)
- Shepel AI, Klementyeva TN, Melnik AG. Waterfowl and Nearwater Birds of Man-Made Reservoirs and Ponds in the City Perm and Their Protection. In: *Proceedings of the All-Russian Scientific and Practical Conference Dedicated to the 25th Anniversary of the Union for the Conservation of Birds in Russia "Topical Issues in Bird Conservation" (Moscow, February 10–11, 2018)*. Moscow–Makhachkala: Union for the Conservation of Birds in Russia; 2018. P. 219–222. (In Russ.)
- Matveyeva GK, Demytyeva VV, Lapushkin VA, Kazakov VP, Kharin RV, Vasyukov SM. On the Distribution of Some Bird Species in the Perm Region. *Fauna of the Urals and Siberia*. 2024;(1):41–47. (In Russ.)
- Khokhutkin IM, Vinarsky MV. *Mollusks of the Urals and Adjacent Territories. Families Acroloxidae, Physidae, Planorbidae (Gastropoda, Pulmonata, Lymnaeiiformes). Part 2*. Ekaterinburg: Goshchitsky; 2013. 184 p. (In Russ.)
- Andreeva SI, Andreev NI, Vinarsky M.V. *Key to Freshwater Gastropods (Mollusca: Gastropoda) of Western Siberia. Part 1. Gastropoda: Pulmonata. Issue 1. Families Acroloxidae and Lymnaeidae*. Omsk; 2010. 200 p. (In Russ.)

18. Alekseev VR and Tsalolikhin SYa (Eds). *Identifier of Zooplankton and Zoobenthos of Fresh Waters of European Russia. Vol. 2. Zoobenthos*. Moscow–Saint Petersburg: Tovarishchestvo nauchnykh izdaniy KMK; 2016. 457 p. (In Russ.)
19. Cherepanov AA, Moskvina AS, Kotelnikov GA, Khrenov VM. *Atlas. Differential Diagnostics of Helminthiasis Based on the Morphological Structure of Pathogens' Eggs and Larvae*. Moscow: Rosselkhozakademiya; 2002. 85p. (In Russ.)
20. Ataeva GL, Kozminsky EV, Dobrovolskiy AA. Dynamics of Infection of Bithynia Tentaculata (Gastropoda: Prosobranchia) with Trematodes. *Parasitology*. 2002;3(36):203–218. (In Russ.)
21. Maiurova AS, Kustikova MA. Features of the First Intermediary Host Distribution of *Opisthorchis Felinus* near Major Cities of the KhMAO — Ugra (Western Siberia). *Environmental and Human Ecological Studies*. 2019;9(4):481–501. (In Russ.)
22. Vinogradova AA, Prochorova EE. Species Identification of Trematodes from Notocotylidae Family Infesting Ducks. In: Proceedings of the VIII All-Russian Conference with International Participation “School on Theoretical and Marine Parasitology” (Sevastopol, September 12–16, 2022). Sevastopol: Federal Research Center “Institute of Southern Sea Biology of the Russian Academy of Sciences named after A. O. Kovalevsky”; 2022. P. 29. (In Russ.)
23. Diaz JI, Gilardoni C, Lorenti E, Cremonte F. *Notocotylus Pprimulus* n. sp. (Trematoda: Notocotylidae) from the Crested Duck *Lophonetta Specularioides* (Aves, Anatidae) from Patagonian Coast, Southwestern Atlantic Ocean. *Parasitology International*. 2020;74:101976. <https://doi.org/10.1016/j.parint.2019.101976>
24. Mir MR, Shah GM, Jan U. Incidence and Epidemiology of *Notocotylus Attenuates* Diesing, 1839 in Mallard Ducks (*Anas platyrhynchos*) in Various Wetlands of Pampore, Kashmir, Jkut, India. *Sustainability and Biodiversity Conservation*. 2022;1(1):84–88. <https://doi.org/10.5281/zenodo.7135072>
25. Sasaki M, Kobayashi M, Yoshino T, Asakawa M, Nakao M. *Notocotylus Ikutai* n. sp. (Digenea: Notocotylidae) from Lymnaeid Snails and Anatid Birds in Hokkaido, Japan. *Parasitology International*. 2021;83:102318. <https://doi.org/10.1016/j.parint.2021.102318>
26. Klabukov AS, Sivkova TN. Parasites in Voles at the Territory around Mahnevskaya Ice Cave (Perm Region). *Russian Journal of Parasitology*. 2020;21:133–136. (In Russ.) <https://doi.org/10.31016/978-5-9902341-5-4.2020.21.133-136>
27. Graczyk TK, Shiff CJ. Experimental Infection of Domestic Ducks and Rodents by *Notocotylus Attenuatus* (Trematoda: Notocotylidae). *Journal of Wildlife Diseases*. 1993;29(3):434–439. <https://doi.org/10.7589/0090-3558-29.3.434>

About the Authors:

Tatiana N. Sivkova, Dr.Sci. (Biology), Professor of the Department of Infectious Diseases, Perm State Agro-Technological University (23, Petropavlovskaya Str., Perm, 614990, Russian Federation), [SPIN-code](#), [ORCID](#), [Researcher ID](#), [Scopus ID](#), tatiana-sivkova@yandex.ru

Darya A. Lokteva, Postgraduate Student of the Department of Infectious Diseases, Perm State Agro-Technological University (23, Petropavlovskaya Str., Perm, 614990, Russian Federation), [SPIN-code](#), [ORCID](#), [Researcher ID](#), lokteva.dascha@yandex.ru

Margarita V. Khazova, Postgraduate Student of the Department of Infectious Diseases, Perm State Agro-Technological University (23, Petropavlovskaya Str., Perm, 614990, Russian Federation), [SPIN-code](#), [ORCID](#), margaritka92@bk.ru

Claimed Contributorship:

TN Sivkova: scientific supervision, development of the concept, coprological research, preparing the article.

DA Lokteva: research in the molluscs, preparing the article.

MV Khazova: research in birds.

Conflict of Interest Statement: the authors declare no conflict of interest.

All authors have read and approved the final manuscript.

Об авторах:

Татьяна Николаевна Сивкова, доктор биологических наук, доцент, профессор кафедры инфекционных болезней Пермского государственного аграрно-технологического университета имени академика Д.Н. Прянишникова (614990, Российская Федерация, г. Пермь, ул. Петропавловская, д. 23), [SPIN-код](#), [ORCID](#), [Researcher ID](#), [Scopus ID](#), tatiana-sivkova@yandex.ru

Локтева Дарья Александровна, аспирант кафедры инфекционных болезней Пермского аграрно-технологического университета имени академика Д.Н. Прянишникова (614990, Российская Федерация, г. Пермь, ул. Петропавловская, д. 23), [SPIN-код](#), [ORCID](#), [Researcher ID](#), lokteva.dascha@yandex.ru

Хазова Маргарита Валерьевна, аспирант кафедры инфекционных болезней Пермского аграрно-технологического университета имени академика Д.Н. Прянишникова (614990, Российская Федерация, г. Пермь, ул. Петропавловская, д. 23), [SPIN-код](#), [ORCID](#), margaritka92@bk.ru

Заявленный вклад авторов:

Т.Н. Сивкова: научное руководство, разработка концепции, копрологические исследования, подготовка статьи.

Д.А. Локтева: исследования моллюсков, подготовка статьи.

М.В. Хазова: исследование птиц.

Конфликт интересов: авторы заявляют об отсутствии конфликта интересов.

Все авторы прочитали и одобрили окончательный вариант рукописи.

Received / Поступила в редакцию 25.01.2026

Reviewed / Поступила после рецензирования 20.02.2026

Accepted / Принята к публикации 23.02.2026

PARASITOLOGY

ПАРАЗИТОЛОГИЯ



UDC 619:616.995.122

<https://doi.org/10.23947/2949-4826-2026-25-1-17-25>

Literature Review

The Small Pond Snail (*Lymnaea truncatula*) and Its Role in Spreading Trematodiasis. The Situation in the Kaluga Region: Literature Review



EDN: ASCIVC

 Yaroslav S. Morozov , Anna M. Nikanorova 

Kaluga State University named after K.E. Tsiolkovsky, Kaluga, Russian Federation

✉ 13579adh@mail.ru

Abstract

Introduction. The small pond snail (*Lymnaea truncatula*) acts not only as a vector for certain species of helminths but also as a universal intermediate host ensuring the circulation of a wide range of trematodes. The increased number of these parasites is a matter of significant epizootological and epidemiological concern as they are posing a threat to the health of humans and farm animals. The aim of the present review is to summarize the available ecology, parasitology, veterinary and epidemiology science data regarding *L. truncatula* and its role in spreading the trematodiasis, particularly in the Kaluga Region.

Materials and Methods. The following science citation databases were used: Google Scholar, PubMed, Web of Science, CyberLeninka, Russian Index of Science Citation (RISC/РИИЦ), and others. The publications in Russian and English of the period of 2010–2023 were selected by the keywords: *L. truncatula*, trematodiasis, fascioliasis, microcoeliasis, Kaluga Region. Articles that were not peer-reviewed and data without statistical verification were excluded. The results were presented in a PRISMA flow chart.

Results. It has been established that the small pond snail plays a key role in the transmission of fascioliasis and is also potentially involved in the spread of other trematodiasis. The main factors affecting spreading the infestation include hydrothermal conditions, high soil water capacity, livestock grazing intensity, and the state of melioration system. In the Kaluga Region, the mollusk population density in floodplain biotopes reaches 60–70 specimens/m², and the infestation rate reaches 23%, which creates the stable foci of infestation. The periods of greatest epizootic danger last from June to September. For the efficient control and prevention of trematodiasis in the region, a comprehensive approach is required, which combines reclamation works, the use of molluscicides, and modern monitoring systems, as well as systemic collaboration between the specialists of veterinary, agricultural and research institutions.

Discussion and Conclusion. When interpreting the results of the present review, it is necessary to remember the limitations typical for this type of research: the risk of biased evaluation of studies due to the predominance of the publications with positive or statistically significant results in the analysed citation databases; the heterogeneity of the included studies, which complicates direct data comparison; the geographical and temporal limitations of data by region, etc. The following areas of research can be of potential importance in the future: studying the influence of the mollusk microbiome on their resistance to infestation; evaluating the efficiency of new biological control methods; and studying the impact of climate changes on parasitic systems. The data obtained will enable the development of a scientifically based trematodiasis control system adapted to the Kaluga Region conditions.

Keywords: literature review, small pond snail, *Lymnaea truncatula*, trematodiasis, fascioliasis, microcoeliasis, Kaluga Region, intermediate hosts, epizootological monitoring, control measures

For Citation. Morozov YaS, Nikanorova AM. The Small Pond Snail (*Lymnaea truncatula*) and Its Role in Spreading Trematodiasis. The Situation in the Kaluga Region: Literature Review. *Russian Journal Veterinary Pathology*. 2026;25(1):17–25. <https://doi.org/10.23947/2949-4826-2026-25-1-17-25>

Малый прудовик (*Lymnaea truncatula*) и его роль в распространении трематодозов. Ситуация в Калужской области. Обзор научной литературы

Я.С. Морозов  , А.М. Никанорова 

Калужский государственный университет имени К.Э. Циолковского, г. Калуга, Российская Федерация

 13579adh@mail.ru

Аннотация

Введение. Малый прудовик (*Lymnaea truncatula*) выступает не только как биологический переносчик отдельных видов гельминтов, но и как универсальный промежуточный хозяин, обеспечивающий циркуляцию широкого спектра трематод. Большое число этих паразитов характеризуется выраженной эпизоотологической и эпидемиологической значимостью, представляя угрозу для здоровья человека и сельскохозяйственных животных. Цель обзора — обобщить имеющиеся данные экологии, паразитологии, ветеринарии и эпидемиологии, касающиеся *L. truncatula* и его роли в распространении трематодозов, в частности, в условиях Калужской области.

Материалы и методы. Использованы базы данных Google Scholar, PubMed, Web of Science, CyberLeninka, РИНЦ и др. Отбор публикаций на русском и английском языках проводился за период 2010–2023 гг. по ключевым словам: *L. truncatula*, трематодозы, фасциолез, дикроцелиоз, Калужская область. Исключены статьи без рецензирования и данные без статистической проверки. Результаты отбора оформлены в виде блок-схемы PRISMA.

Результаты исследования. Установлено, что малый прудовик играет ключевую роль в передаче фасциолеза, а также потенциально вовлечён в циркуляцию других трематодозов. Основными факторами передачи инвазии являются гидротермический режим, высокая влагоемкость почв, интенсивность выпаса скота и состояние мелиоративных систем. В Калужской области плотность популяций моллюска в пойменных биотопах достигает 60–70 экз./м², а уровень их зараженности — 23 %, что создает устойчивые очаги инвазии. Периоды наибольшей эпизоотической опасности — июнь–сентябрь. Эффективный контроль и профилактика трематодозов в регионе требует интегрированного подхода, сочетающего мелиоративные мероприятия, применение моллюскоцидов и современных систем мониторинга, а также системного взаимодействия специалистов ветеринарных служб, аграрных предприятий и научных учреждений.

Обсуждение и заключение. При интерпретации результатов настоящего обзора необходимо учитывать ряд ограничений, характерных для работ данного типа: риск необъективной оценки исследований, связанный с тем, что в анализируемых базах данных преобладают публикации с положительными или статистически значимыми результатами; неоднородность включенных исследований, затрудняющих прямое сопоставление данных; географическую и временную ограниченность данных по региону и др. Перспективными направлениями для дальнейших исследований являются: изучение влияния микробиома моллюсков на их устойчивость к заражению; оценка эффективности новых биологических методов контроля; исследование влияния климатических изменений на паразитарные системы. Полученные данные позволят разработать научно обоснованную систему контроля трематодозов, адаптированную к условиям Калужской области.

Ключевые слова: обзор научной литературы, малый прудовик, *Lymnaea truncatula*, трематодозы, фасциолез, дикроцелиоз, Калужская область, промежуточные хозяева, эпизоотологический мониторинг, меры борьбы

Для цитирования. Морозов Я.С., Никанорова А.М. Малый прудовик (*Lymnaea truncatula*) и его роль в распространении трематодозов. Ситуация в Калужской области. Обзор научной литературы. *Ветеринарная патология*. 2026;25(1):17–25. <https://doi.org/10.23947/2949-4826-2026-25-1-17-25>

Introduction. The small (dwarf) pond snail (*Lymnaea truncatula*) belongs to the phylum Mollusca, class Gastropoda, order Pulmonata, family Lymnaeidae [1]. The species is widespread in the temperate climatic zone of Eurasia, mainly in marshy meadows, river floodplains, wet gullies and the margins of small water bodies [2, 3]. Due to being an intermediate host for trematodes of the family Fasciolidae, the small (dwarf) pond snail represents a significant veterinary and public health problem in the regions with well-developed livestock farming [4]. For example, the Kaluga Region, with its favourable natural and climatic

conditions for the development of mollusks, is considered to be an area with the persistent foci of fascioliasis [5, 6]. According to the Veterinary Department of the Kaluga Region, trematodiasoses refer to the cattle helminthiases most seriously affecting the economy of the region [7]. Constant monitoring, taxonomic clarification of the malacofauna, and implementation of the preventive measures are necessary in the regions of traditional livestock farming, in suburban, recreational and tourist territories [2, 8].

The present review summarizes the available scientific data on the ecological aspects in biology of *L. truncatula*,

its role as an intermediate host, current trends in the incidence of fascioliasis, and modern approaches to controlling the population of intermediate hosts and reducing the risk of spreading the trematodiasis. It also summarizes present-day knowledge on the role of the small (dwarf) pond snail in spreading trematodiasis in agricultural animals on the example of the Kaluga Region. Particular attention is paid to identifying a set of factors that determine the formation and continuance of persistent foci of infestation within the region borders.

Materials and Methods. A search for literature was conducted in the following citation databases: Google Scholar, PubMed, Web of Science, MedLine, the Cochrane Library, EMBASE, Global.health, CyberLeninka, and Russian Index of Science Citation (RISC/РИИЦ).

Only Russian- and English-language publications published between 2010 and 2023 were included in the search. The following keywords and their combinations were used: *Lymnaea truncatula*, trematodiasis, fascioliasis, dicrocoeliasis, Kaluga Region.

The criteria for including the publications in the review were: provision of original data, relevance to the topic of the study, and peer-reviewed type of the publications. Articles that were not peer-reviewed, did not present statistical data processing, and were not directly related to the species studied (the intermediate host — *L. truncatula*) were excluded from the review.

The process of literature sources' selection was documented in compliance with PRISMA guidelines. The first stage consisted of screening the titles and abstracts, and the second involved studying the full texts of potentially appropriate publications. The results of the search and step-by-step exclusion of publications are presented in the flowchart.

Research Results. A total of 146 publications were distinguished as a result of citation database search. Additionally, 3 sources were found upon manual search (monographs, methodological manuals). After removing 28 duplicate records, the total number of publications for analysis was 121. Then, after title and abstract screening, 74 publications were deemed to have a topic irrelevant to the present study and therefore were excluded. Potentially relevant full text publications (n=44) were reviewed by experts. After this step, 8 more publications were excluded (due to the low quality of statistics processing or unavailability of the full texts). Eventually, 36 highly relevant to the topic articles were selected for the review. A summary of verification process is shown in the PRISMA flowchart (Fig. 1).

Biology and ecology of *L. truncatula*. The small (dwarf) pond snail inhabits temporary water bodies, ditches, and marshy meadows, where it actively reproduces

in spring and the first half of summer. This eurythermal species is capable of adapting to a wide range of hydrothermal conditions, including conditions of temperate and sub-boreal climates. Maximum mollusk numbers are observed in August — up to 68 specimens/m². The life cycle of *Fasciola hepatica* requires a body of an intermediate host for rediae and cercariae to form. At temperature of 15–25 °C, the evolution completes within 5–7 weeks [4]. Cercariae leave the mollusk and encyst on plants as adolescaria that can cause harm to agricultural animals while eating the grass.

Molecular genetic methods make it possible to detect hidden genetic diversity of mollusks, i.e. to distinguish between the forms that look similar but may play different roles in the transmission of parasites [4].

The period between July and September is the time of highest infestation risk for the small (dwarf) pond snail, especially in pastures with moist soil and ditches. Seasonal fluctuations in population size depend on hydrothermal conditions, competition with other species, and livestock density. By using the normalized difference vegetation index (NDVI), as well as humidity and temperature data, it is possible to construct the accurate risk charts [4].

Natural and climatic conditions of the Kaluga Region contributing to prevalence and population size of *L. truncatula*. The Kaluga Region is a unique region for studying the ecology of *L. truncatula* due to combination of favourable natural and climatic conditions [6]. The conducted analysis allows for identifying several key aspects that determine the prevalence and population size of this mollusk species in the region.

The region is characterized by the temperate continental climate with distinct seasonality. Annual mean precipitation is 550–650 mm, with approximately 70% falling in the spring and summer period, which creates optimal conditions for mollusk development. Temperature conditions are also favourable for mollusk existence: mean July temperature is +18 °C; January — approximately -10 °C. A particularly important factor is the duration of the frost-free period (approximately 140–150 days), which allows both the mollusks and the associated trematodes to complete the full life cycle [3, 6].

The hydrological network of the region includes major waterways such as the Oka, Ugra, and Zhizdra rivers. These rivers and their numerous tributaries form extensive floodplain ecosystems — the ideal habitats for *L. truncatula* [6, 9]. Of particular importance are the numerous temporary water bodies, which retain water throughout the mollusk growing season. According to hydrobiological studies, these temporary water bodies prove to have the highest mollusk population densities [2, 10].

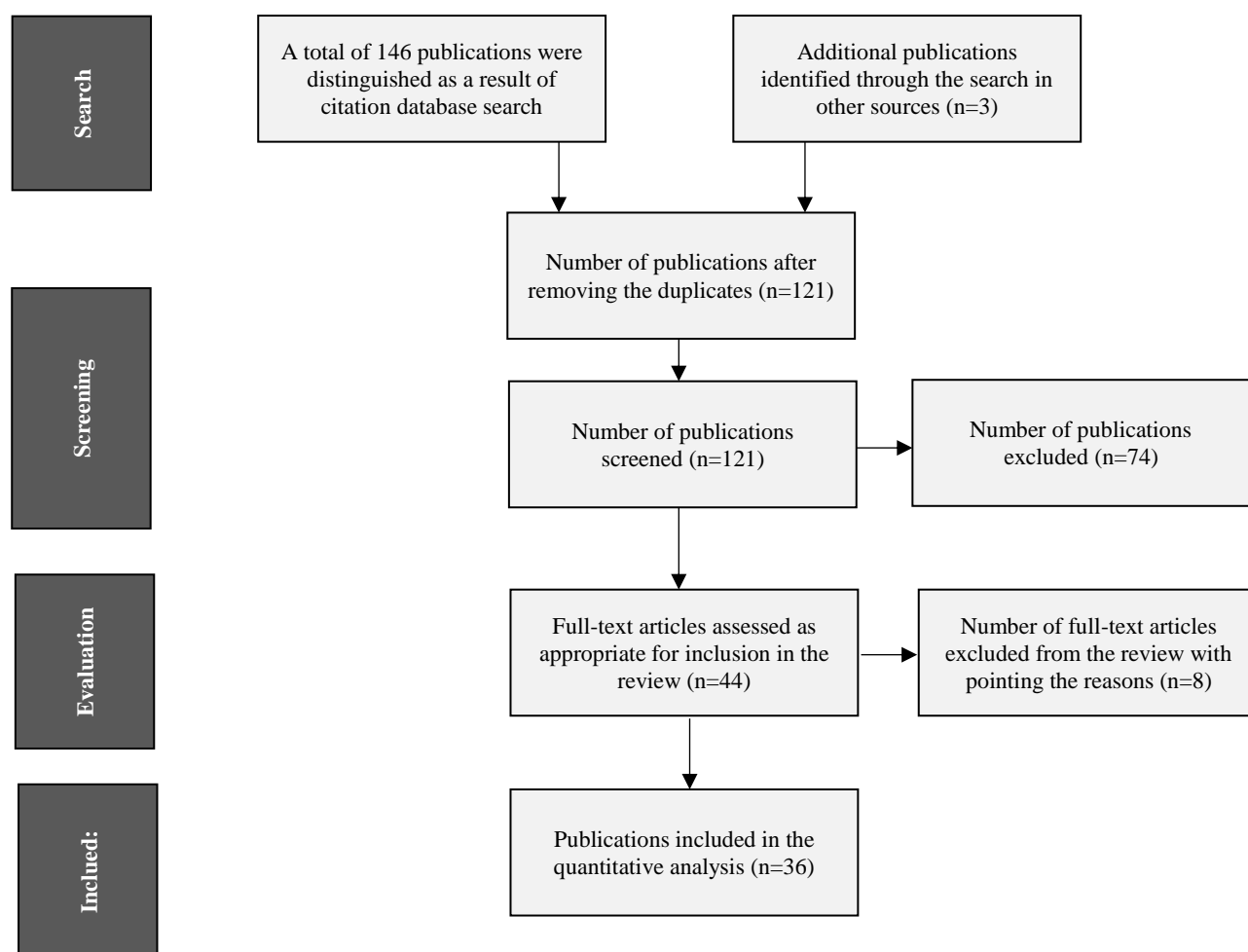

Fig. 1. PRISMA flow chart showing the results of publications' selection process

The predominance of sod-podzolic and alluvial soils in the region creates optimal conditions for the existence of mollusks. These soils are characterized by:

- high water capacity;
- abundant concentration of organic matter;
- pH neutral or slightly acidic environment;
- a well-developed capillary water system, which maintains the necessary moisture level even during short-term drying out of the water bodies [5, 6].

The main *L. truncatula* biotopes in the Kaluga Region include floodplain meadows, drainage ditches, and temporary water bodies in the pastures [6]. Population density reaches 60–70 specimens/m². Temporary water bodies play a key role in maintaining trematodiasis foci due to:

- rapid warming of water;
- abundant vegetation;
- regular circulation of trematode eggs with animal faeces;
- the absence of planktophagous fish [4, 10].

The Kaluga Region is referred to the industrially developed regions, yet significant attention is paid to the development of ecotourism. The region has the protected natural areas, such as the Ugra National Park, Kaluzhskie Zaseki Nature Reserve, and private eco-farms “Jersey” and

“Happy Farm”. These areas contribute to the conservation of natural ecosystems and biotopes, which are home, to the small (dwarf) pond snail, an important intermediate host for trematodes [4].

The seasonal dynamics of the small (dwarf) pond snail population in the region exhibits a distinctly bimodal pattern, with peaks in late spring (May–June) and late summer (August–September). Minimum values are observed in October, before the mollusks leave for wintering [3, 7].

Fascioliasis and its causative agent. Fascioliasis is a helminthiasis caused by the liver fluke *Fasciola hepatica*, affecting domestic and wild ruminants, as well as humans. *L. truncatula* is the primary and obligate first-intermediate host for this parasite. The life cycle includes: egg → miracidium → sporocyst → redia → cercaria → adolescaria. Infestation occurs after ingestion of vegetation or water contaminated with adolescariae [11].

The economic damage from fascioliasis is significant: the estimated number of infested people and animals equals to millions of cases annually [9]. The expansion of *L. truncatula* habitat upon the influence of climate changes, increases the risk of emergence of new foci of infestation [12, 13]. Most

vulnerable are the regions with pasture husbandry, where there is a lack of systemic monitoring of intermediate hosts.

In humans, fascioliasis is manifested by fever, pain in the right hypochondrium, eosinophilia, and liver enlargement. In agricultural animals, it is manifested by anaemia, decreased productivity, cachexia, and liver and bile duct damage [4].

Other trematodiasis associated with *L. truncatula*.

Dicrocoeliasis is caused by *Dicrocoelium dendriticum* that parasitizes in the liver of herbivores. The first hosts are terrestrial mollusks of the genus *Zebrina*, *L. truncatula*. Transmission occurs through infested ants (the second-intermediate hosts), which are ingested by the animals. The parasite causes chronic liver damage, bile duct fibrosis, and reduced productivity in cattle [11].

Opisthorchiasis is caused by *Opisthorchis felineus*. The first intermediate hosts are mollusks of the genus *Bithynia*. However, as noted by M.V. Vinarsky, in some cases, for example, when the ecological balance is disturbed, *L. truncatula* may be involved as a transit or atypical intermediate [2, 6]. Such cases have been recorded in river basins with high aquatic biomass density, and with introduction of new species [10]. Animals become infested through consumption of raw or insufficiently processed fish containing metacercariae. This causes hepatobiliary disorders, and bears the risk of cholangitis, and even cholangiocarcinoma [11].

Fascioliasis, caused by *Fasciola gigantica*—the giant liver fluke widely spread in southern regions, but due to global warming, its northern expansion is possible. *L. truncatula* can temporarily replace native species *Lymnaea auricularia* or *Radix spp.*, especially in hybrid zones of its habitat [9].

Echinostomatidosis (caused by *Echinostoma revolutum*) can occur in *L. truncatula* in experimental conditions. Infestation occurs through ingestion of cercariae. In humans and birds, it causes intestinal inflammation, pain, fever, and diarrhea [11].

Polyinfestations—a combination of *F. hepatica* with *Paramphistomum cervi* or other trematodes—are possible in mollusks in water bodies with high fecal contamination and temperatures above 20°C. Such polyinfestations increase the severity of the parasite load in ruminants [10].

The exotic species *Schistosoma mansoni* is not yet transmitted by *L. truncatula* and does not represent a biomedical threat so far. However, in the event of artificial introduction and global climate change, the mollusk may participate in atypical cycles in laboratory settings. This emphasises the potential danger of spreading this trematodiasis in other epidemiological chains too [13].

Among all trematodiasis, fascioliasis remains the most significant one, but expansion of habitat, hybridization of trematodes, global warming, and changes in the economic pattern create conditions for pond snail involvement in the new parasitic systems [4].

The following recent trends remain a pressing problem:

- expansion of the trematode species using *L. truncatula* as a host;
- increase of the infestation level in mollusks;
- the emergence of new foci of infestation,

These changes may be related to climatic changes, anthropogenic transformation of landscapes, intensification of livestock farming, and changes in the grazing system [13, 14].

Trematodiasis Transmission Factors. Factors determining the intensity of trematodiasis transmission in the Kaluga Region can be divided into three groups:

1. Natural factors:

- hydrothermal regime: optimal water temperature (15–25°C), sufficient precipitation, duration of the growing period [3, 6];
- water body characteristics: depth (shallow areas are preferred), flow velocity (stagnant or slow-moving waters), high degree of vegetation overgrowth [10];
- soil conditions: composition, water capacity, organic matter concentration [5, 6].

2. Anthropogenic factors:

- land use pattern: grazing intensity (critical threshold: 2.5 heads/ha), rotation of pasture areas, availability of watering places [4, 5];
- state of melioration systems: degree of waterlogging, drainage quality, regularity of ditch cleaning [9, 10];
- economic activity: use of fertilizers, use of pesticides, haymaking [15].

3. Climatic changes:

- Temperature increase: increased period of mollusk activity, accelerated development of trematodes, expansion of the *L. truncatula* habitat [12, 13];
- Changes in precipitation patterns: increased number of temporary water bodies, changes in the hydrological regimes, redistribution of mollusk populations [12, 13];
- Extreme events: droughts, floods, abnormally warm winters [12, 13].

The analysis has revealed the correlation between the degree of anthropogenic load on water bodies, the level of mollusk infestation, and the intensity of trematodiasis transmission.

Trematode population control and prevention of trematodiasis. To reduce the incidence of trematodiasis

in humans and animals, it is necessary to control *L. truncatula* population size in the pastures using molluscicides (based on niclosamide) during the periods of greatest mollusk activity (late May – early August) [9, 16]. The use of biological methods, e.g., introduction of predatory aquatic insects (*Hydrophilidae*, *Dytiscidae*) to limit the dwarf pond snail population size is now studied in the international practice [17]. It is recommended to inspect the sanitary condition of territories, especially near water bodies for implementing a set of measures aimed at controlling the populations of intermediate hosts [9].

One of the primary preventative measures is controlling *L. truncatula* population size in natural and anthropogenic biotopes. This is particularly valid for floodplain pastures and temporary water bodies, where conditions are optimal for the mollusk and, consequently, for the transmission of infestation. It is important to consider weather and climate conditions, because high humidity and warm temperatures stimulate the reproduction of the pond snail and accelerate the development of parasites [10]. The monitoring system represents a complex process, which incorporates both biological and sanitary measures. Based on the analysis of the efficiency of various methods, the following key directions of *L. truncatula* population control and prevention of associated trematode infestations in the Kaluga Region can be distinguished:

- pasture reclamation: draining temporary water bodies, soil liming, deep ploughing of marshy areas, demolition of aquatic vegetation and weeds thickets — all this leads to a decrease in the number of intermediate hosts [9];
- for local natural foci where large-scale reclamation works are impossible (e.g., in nature reserves or ecotourism areas), a biological method can be used: the release of molluscivorous fish species (*Misgurnus fossilis*, *Tinca tinca*) and birds capable of regulating the population size of *L. truncatula* [17];
- deworming of cattle using fasciolicides (albendazole, triclobendazole, oxcyclozanide, etc.): the frequency of treatment depends on the epizootic situation and the epidemic season phases. The most efficient time for carrying out treatment is early spring (before turning cattle out to pasture) and late autumn (before stall keeping) [16, 18]. The use of molluscicides, despite their efficacy, requires consideration of the impact on the balance of aquatic ecosystems [1, 17, 18];
- a comprehensive approach that combines: environmentally friendly methods of population control [17]; mod-

ern monitoring technologies (GIS technology, PCR diagnostics) [8, 14, 19]; scientifically based forecasting [14, 20]; adaptive management of pasture lands [9].

The comprehensive approach proves to be the most future-oriented method enabling achievement of a sustainable effect with minimal impact on the ecosystems and maximum economic efficiency [9, 17].

Research Limitations. When interpreting the results of the present review, it is necessary to consider a number of limitations typical of this type of work. Firstly, there is a risk of bias evaluation of studies due to the predominance of publications with positive or statistically significant results in the analysed citation databases. Studies that failed to find a correlation between *L. truncatula* and prevalence of trematodiasoses or showing negative results might not have been published, which potentially could distort the overall picture.

Secondly, the heterogeneity of the included studies complicates direct comparison of data: differences in the methods of field data collection, mollusk infestation diagnostic criteria, seasonal timing of research, and statistical data processing techniques could have influenced the variability of the presented indicators (e.g., population densities from 9 to 70 specimens/m²).

Thirdly, the presented data are limited by their geography and time: a significant portion of the sources discovered for the Kaluga Region refer to the period 2016–2022, which may not fully reflect the current epizootic situation, especially in the context of rapid climate changes in the recent years. Furthermore, data for a number of biotopes in the region are fragmented or absent.

Fourthly, uncertainty remains in the taxonomic identification of mollusks in early-dated studies. Before the widespread implementation of molecular genetic methods, *L. truncatula* was identified solely by morphological characteristics, which could lead to the erroneous attribution of the closely related species to this taxon and, consequently, to inaccuracies in assessing its actual role in the transmission of infestations [10, 14].

Finally, language limitations (inclusion of only Russian- and English-language publications) could have led to the exclusion of relevant studies published in other languages.

Taking into account the above limitations, it is possible to have a more balanced approach to the interpretation of the findings and defining directions for further research.

Discussion and Conclusion. Based on the results of the review of the scientific literature, the following conclusions can be drawn:

1. The small (dwarf) pond snail *L. truncatula* plays a key role in the transmission of several species of trematodes, primarily *Fasciola hepatica*.

2. The Kaluga Region has a unique combination of natural and climatic conditions favourable for development of persistent *L. truncatula* populations. These are: temperate continental climate, a well-developed hydrological network, and the predominance of sod-podzolic soils [5, 6].

3. The level of trematode infestation in mollusks in various biotopes of the region reaches 23%, creating a constant threat of infestation foci emergence [6, 10]. The formation of trematode foci is induced by a combination of interrelated natural and anthropogenic factors, including hydrothermal conditions, grazing intensity, and the state of melioration systems [5, 7, 9].

4. The ecological condition of the Kaluga Region is complicated by the anthropogenic load: pollution of air and water bodies, accumulation of wastes, and erosion of soils [6, 15]. These factors affect the stability of wetland ecosystems, which are home to mollusks—the intermediate hosts of parasites [10, 19].

5. The most efficient strategy for controlling the mollusk population size is implementation of a comprehensive approach that combines reclamation measures, the use of molluscicides, biological methods, and modern monitoring systems [9, 17, 18].

6. Prophylaxis should be adaptive, taking into account natural and climatic fluctuations, as well as the features of certain landscapes [7, 12, 13, 20, 21].

Efficient control of trematodiasis natural foci is impossible without systemic collaboration between the specialists of veterinary services, agricultural enterprises, environmental protection agencies and scientific institutions [5, 6, 9, 22, 23, 24].

The potential areas for further research include:

— studying the influence of mollusks' microbiome on their resistance to infestation;

— evaluating the efficiency of new biological control methods;

— studying the impact of climate changes on parasitic systems.

Research in these areas will enable the development of a scientifically based system of controlling trematodiasis adapted to the Kaluga Region conditions and taking into account current environmental changes.

Список литературы/References

1. Kantor YuI, Sysoev AV. *Marine and Brackish-Water Gastropods of Russia and Adjacent Countries: Illustrated Catalogue*. Moscow: KMK; 2006. 372 p. (In Russ.)
2. Prozorova LA, Vinarski MV. Annotated List of Freshwater Mollusks of Russia and Adjacent Territories. *Ruthenica*. 2016;26(1):1–56. (In Russ.)
3. Manakov DV, Vinarski MV. Ecological Physiology of Freshwater Gastropods: A Review. *Hydrobiological Journal*. 2015;47(3):45–60. (In Russ.)
4. Alba A, Vazquez AA, Hurtrez-Boussès S. Towards the Comprehension of Fasciolosis (Re-) Emergence: An Integrative Overview. *Parasitology*. 2021;148(4):385–407. <https://doi.org/10.1017/s0031182020002255>
5. Safiullin AM, Ustinov AM, Mukaseev SV. Prevalence of *Fasciola hepatica* of cattle in the Russian Federation and in the Kaluga Region. *Theory and Practice of Parasitic Disease Control*. 2010;16(1):422–425. (In Russ.)
6. Vinarski MV, Kantor YuI. Mollusks of Russia and Adjacent Countries: Diversity and Distribution. *Biological Communications*. 2016;61(2):99–120. (In Russ.)
7. Ustinov AM, Safiullin RT, Safiullin RR. Methodical Guidelines on the Control of Fasciolosis in Cattle in the Kaluga Region. *Russian Journal of Parasitology*. 2018;12(2):108–116. <https://doi.org/10.31016/1998-8435-2018-12-2-108-116> (In Russ.)
8. Beesley NJ, Caminade C, Charlier J, Flynn RJ, Hodgkinson JE, Martinez-Moreno A, et al. Fasciola and Fasciolosis in Ruminants in Europe: Identifying Research Needs. *Transboundary and Emerging Diseases*. 2018;65(Suppl 1):199–216. <https://doi.org/10.1111/tbed.12682>
9. WHO, CABI. *Fasciolosis: Epidemiology, Diagnosis, and Control*. Wallingford: CABI Publishing; 2021. 240 p.
10. Skryabin KI. *Trematodes of Animals and Humans. Fundamentals of Trematodology*. Moscow: Nauka; 1951. 600 p. (In Russ.)
11. Mas-Coma S, Valero MA, Bargues MD. Fascioliasis. *Advances in Experimental Medicine and Biology*. 2019;1154:71–103. http://doi.org/10.1007/978-3-030-18616-6_4
12. Short EE, Caminade C, Thomas BN. Climate Change Contribution to the Emergence or Re-Emergence of Parasitic Diseases. *Infect. Dis. (Auckl)*. 2017;25(10):1178633617732296. <http://doi.org/10.1177/1178633617732296>

13. Garcia-Corredor D, Alvarado M, Pulido-Medellín M, Muñoz M, Cruz-Saavedra L, Hernández C, et al. Molecular Characterization of *Fasciola Hepatica* in Endemic Regions of Colombia. *Frontiers in Veterinary Science*. 2023;10:1171147. <http://doi.org/10.3389/fvets.2023.1171147>
14. Kantor YuI, Sysoev AV. *Catalogue of Mollusks of Russia and Adjacent Countries*. Moscow: KMK; 2005. 527 p. (In Russ.)
15. Sabourin E, Alda P, Vázquez A, Hurtrez-Boussès S, Vittecoq M. Impact of Human Activities on Fasciolosis Transmission. *Trends in Parasitology*. 2018;34(10):891–903. <https://doi.org/10.1016/j.pt.2018.08.004>
16. Caminade C, van Dijk J, Baylis M, Williams D. Modelling Recent and Future Climatic Suitability for Fasciolosis in Europe. *Geospatial Health*. 2015;9(2):301–308. <http://doi.org/10.4081/gh.2015.352>
17. Azmi WA, Khoo SC, Ng LC, Baharuddin N, Aziz AA, Ma NL. The Current Trend in Biological Control Approaches in the Mitigation of Golden Apple Snail *Pomacea* Spp. *Biological Control*. 2022;175:105060. <https://doi.org/10.1016/j.biocontrol.2022.105060>
18. Fairweather I, Brennan GP, Hanna REB, Robinson MW, Skuce PJ. Drug Resistance in Liver Flukes. *International Journal for Parasitology: Drugs and Drug Resistance*. 2020;12:39–59. <https://doi.org/10.1016/j.ijpddr.2019.11.003>
19. Cuervo PF, Mera y Sierra R, Artigas P, Fantozzi MC, Bargues MD, Mas-Coma S. Impact of Climate Change on the Spread of Fascioliasis into the Extreme South of South America. *PLOS Neglected Tropical Diseases*. 2025;19(8):e0013433. <https://doi.org/10.1371/journal.pntd.0013433>
20. Nukeri S, Malatji MP, Sithole MI, Ngcamphalala PI, Nyagura I, Tembe D, et al. Infection Rates of *Fasciola* Spp. in Cattle Slaughtered at 13 Abattoirs in Six of Nine Provinces of South Africa. *Food and Waterborne Parasitology*. 2025;39:e00260. <https://doi.org/10.1016/j.fawpar.2025.e00260>
21. Postevoy AN, Gorohov VV, Andreyanov ON. Some Aspects of the Epizootology of Fasciolosis in Ruminant Animals of Central Russia. *Actual Questions of Veterinary Biology*. 2016;(2(30)):22–25. (In Russ.)
22. Flores-Velázquez LM, Ruiz-Campillo MT, Herrera-Torres G, Martínez-Moreno Á, Martínez-Moreno FJ, Zafra R, et al. Fasciolosis: Pathogenesis, Host-Parasite Interactions, and Implication in Vaccine Development. *Frontiers in Veterinary Science*. 2023;10:1270064. <https://doi.org/10.3389/fvets.2023.1270064>
23. Howell AK, Williams DJL. The Epidemiology and Control of Liver Flukes in Cattle and Sheep. *Veterinary Clinics of North America: Food Animal Practice*. 2020;36(1):109–123. <https://doi.org/10.1016/j.cvfa.2019.12.002>
24. Torgerson PR, Devleeschauwer B, Praet N, Speybroeck N, Willingham AL, Kasuga Fumiko, et al. World Health Organization Estimates of the Global and Regional Disease Burden of 11 Foodborne Parasitic Diseases, 2010: A Data Synthesis. *PLoS Medicine*. 2015;12(12):e1001920. <https://doi.org/10.1371/journal.pmed.1001920>

About the Authors:

Yaroslav S. Morozov, Veterinarian, Postgraduate Student of the Department of Biology and Ecology, Institute of Natural Sciences, Kaluga State University named after K.E. Tsiolkovsky (26, Stepan Razin Str., Kaluga, 248023, Russian Federation), [ORCID, 13579adh@mail.ru](mailto:13579adh@mail.ru)

Anna M. Nikanorova, Dr.Sci. (Biology), Professor of the Department of Biology and Ecology, Kaluga State University named after K.E. Tsiolkovsky (26, Stepan Razin Str., Kaluga, 248023, Russian Federation), [SPIN-code](#), [ORCID](#), [Researcher ID](#), [Scopus ID](#), annushkanikanorova@gmail.com

Claimed Contributorship:

YS Morozov: conducting the research, developing research concept and methodology, writing a draft of the manuscript.

AM Nikanorova: scientific supervision, manuscript editing.

Conflict of Interest Statement: the authors declare no conflict of interest.

All authors have read and approved the final manuscript.

Об авторах:

Ярослав Станиславович Морозов, ветеринарный врач, аспирант института естествознания, кафедры биологии и экологии Калужского государственного университета имени К.Э. Циолковского (248023, Российская Федерация, г. Калуга, ул. Степана Разина, д. 26), [SPIN-код](#), [ORCID](#), 13579adh@mail.ru

Анна Михайловна Никанорова, доктор ветеринарных наук, профессор кафедры биологии и экологии Калужского государственного университета имени К.Э. Циолковского (248023, Российская Федерация, г. Калуга, ул. Степана Разина, д. 26.), [SPIN-код](#), [ORCID](#), [Researcher ID](#), [Scopus ID](#), annushkanikanorova@gmail.com

Заявленный вклад авторов:

Я.С. Морозов: проведение исследования, разработка концепции, разработка методологии, написание черновика рукописи.

А.М. Никанорова: научное руководство, редактирование рукописи.

Конфликт интересов: авторы заявляют об отсутствии конфликта интересов.

Все авторы прочитали и одобрили окончательный вариант рукописи.

Received / Поступила в редакцию 11.02.2026

Reviewed / Поступила после рецензирования 06.03.2026

Accepted / Принята к публикации 10.03.2026

ANIMAL PATHOLOGY, MORPHOLOGY, PHYSIOLOGY,
PHARMACOLOGY AND TOXICOLOGY
ПАТОЛОГИЯ ЖИВОТНЫХ, МОРФОЛОГИЯ, ФИЗИОЛОГИЯ,
ФАРМАКОЛОГИЯ И ТОКСИКОЛОГИЯ



UDC 619 (004.891.3)

Original theoretical research

<https://doi.org/10.23947/2949-4826-2026-25-1-26-33>

**Development of an Intelligent System for Diagnosing Rumen Acidosis in Cows.
Part 2: Computer Implementation**



EDN: GHJLEA

Vladimir V. Pobedinskiy¹ , Andrey A. Pobedinskiy²  ✉, Grigory A. Iovlev¹ 

¹ Ural State Agrarian University, Ekaterinburg, Russia

² Tyumen State University, Tyumen, Russia

✉ vm993711@mail.ru

Abstract

Introduction. In the first part of the study, the relevance of improving the methods of rumen acidosis diagnostics in cows based on the intelligent systems was substantiated and the use of fuzzy set theory as a tool for such systems was proposed. The structure of the hierarchical-type intelligent system was developed, and formalization of the problem was completed. In the second part of the study, computer implementation of the fuzzy-logic-based intelligent system for diagnosing acidosis was completed using Xcos tool of Scilab software, and a computer application was developed in the Scilab+Scinotes environment as its practical implementation.

Materials and Methods. The study was conducted at Ural State Agrarian University and Northern Trans-Ural State Agricultural University from 2022 to 2025. The intelligent system techniques, fuzzy set theory and fuzzy logic methods, and Mamdani fuzzy inference system were used to conduct the study. A computer model for rumen pathology assessment was created based on the generalized smart system by means of Xcos tool of Scilab software. Computer implementation of the intelligent system was completed in the Scilab+Scinotes environment.

Results. For solving a problem of hierarchical-type intelligent system, the production rule bases, which included various combinations of diagnostic parameters and respective degrees of rumen acidosis pathology, were developed. Synthesis of fuzzy systems was performed using SciFLT tool of Scilab software. A generalized model of an intelligent system for diagnosing rumen acidosis in cows was developed using Xcos tool of Scilab software. Computer implementation of the intelligent diagnostic system was completed in Scilab software with embedded Scinotes text editor.

Discussion and Conclusion. The model of an intelligent system proposed by the authors is innovative and can be recommended for practical implementation into the expert advisory systems, for automation of veterinary workstations, and for using in modern veterinary telemedicine technologies.

Keywords: rumen acidosis in cows, rumen acidosis pathology, diagnostics, intelligent diagnostic system, fuzzy set theory, computer implementation

For Citation: Pobedinskiy VV, Pobedinskiy AA, Iovlev GA. Development of an Intelligent System for Diagnosing Rumen Acidosis in Cows. Part 2: Computer Implementation. *Russian Journal of Veterinary Pathology*. 2026;25(1):26–33. <https://doi.org/10.23947/2949-4826-2026-25-1-26-33>

Создание интеллектуальной системы диагностирования ацидоза рубца у коров. Часть 2: Компьютерная реализация

В. В. Побединский¹ , А.А. Побединский²  ✉, Г.А. Иовлев¹ 

¹Уральский государственный аграрный университет, г. Екатеринбург, Российская Федерация

²Тюменский государственный университет, г. Тюмень, Российская Федерация

✉ ym993711@mail.ru

Аннотация

Введение. В первой части работы обоснована актуальность совершенствования методов диагностирования ацидоза рубца у коров на базе интеллектуальных систем и предложено использовать в качестве инструментария такой системы теорию нечетких множеств. Была разработана структура интеллектуальной системы иерархического типа и выполнена формализация задач. На втором этапе исследований выполнена компьютерная реализация интеллектуальной нечеткой системы на нечеткой логике диагностирования ацидоза в среде Xcos приложения Scilab, а для практического применения — разработана компьютерная программа в среде Scilab+Scinotes.

Материалы и методы. Исследование проведено в Уральском государственном аграрном университете и Государственном аграрном университете Северного Зауралья в период с 2022 по 2025 гг. Используются методы интеллектуальных систем, теории нечетких множеств, нечеткой логики, нечеткий вывод выполнен методом Мамдани. Программная реализация модели оценки патологии рубца в обобщенной интеллектуальной системе выполнена средствами Xcos приложения Scilab. Компьютерная реализация интеллектуальной системы выполнена в среде Scilab+Scinotes.

Результаты исследования. Созданы базы продукционных правил для задачи интеллектуальной системы иерархического типа, включающие различные сочетания диагностических параметров и соответствующие им степени патологии ацидоза рубца. Проведен синтез нечетких систем в среде SciFLT приложения Scilab. Разработана обобщенная модель интеллектуальной системы диагностирования ацидоза рубца у коров в среде Xcos приложения Scilab. Выполнена компьютерная реализация интеллектуальной системы диагностирования в программах Scilab и Scinotes.

Обсуждение и заключение. Предложенная авторами модель интеллектуальной системы обладает новизной и может быть рекомендована для практического использования в советующих экспертных системах, для автоматизации рабочего места врача-ветеринара, в современных технологиях ветеринарной телемедицины.

Ключевые слова: ацидоз рубца у коров, патология ацидоза рубца, диагностирование, интеллектуальная система диагностирования, теория нечетких множеств, компьютерная реализация

Для цитирования: Побединский В.В., Побединский А.А., Иовлев Г.А. Создание интеллектуальной системы диагностирования ацидоза рубца у коров. Часть 2: Компьютерная реализация. *Ветеринарная патология*. 2026;25(1):26–33. <https://doi.org/10.23947/2949-4826-2026-25-1-26-33>

Introduction. Ensuring sustainable development of animal husbandry is a key objective stipulated in the State Program for the Development of Agriculture in the Russian Federation [1]. Thus, the primary objective of the industry recognized at the government level for the nearest future is annual growth of cattle population and reduction of its mortality¹.

Rumen acidosis is one of the most widespread diseases in cattle. It is called “the prime cause underlying all health problems in cows” [2] and “the most acute problem of any herd, both the high-yielding or ordinary one” [3]. All this justifies the necessity to improve the diagnostics of acidosis at any stage of the disease. For this purpose, we have created an intelligent system for diagnosing rumen acidosis

in cows. At the first stage of the study [4], formalization of the tasks was carried out based on the concept of fuzzy logic: a set of diagnostic parameters for assessing the degree of acidosis pathology was justified; the structure of the hierarchical-type intelligent system was developed; the problem was formalized using the fuzzy set theory methods. The objective of the second part of the study is to complete computer implementation of the earlier formalized fuzzy-logic-based intelligent system for assessing the rumen acidosis pathology in cows.

To achieve this objective, the following tasks were defined:

1) development of the rule bases to solve a problem of hierarchical-type intelligent system;

¹ Strategy for the Development of Agro-Industrial and Fishery Complexes of the Russian Federation for the Period up to 2030. Approved by the Resolution of the Government of the RF No. 2567-r of September 8, 2022.

2) synthesis of fuzzy systems using SciFLT tool of Scilab software;

3) development of a generalized model of an intelligent system for diagnosing rumen acidosis using Xcos tool of Scilab software;

4) computer implementation of the intelligent diagnostic system in Scilab software with embedded Scinotes text editor.

Materials and Methods. The study was conducted at Ural State Agrarian University (Ekaterinburg) and Northern Trans-Ural State Agricultural University (Tyumen) from 2022 to 2025. Methods of veterinary medicine, the intelligent system techniques, fuzzy set theory and fuzzy logic methods, along with Mamdani fuzzy inference system were used to conduct the study. Synthesis of fuzzy systems was performed using SciFLT for Scilab software (Scilab Consortium, France). A computer model for rumen pathology assessment was created based on the generalized smart system by means of Xcos tool of Scilab software. Computer implementation of the intelligent system was completed in the Scilab+Scinotes environment.

Research Results

1. Development of the production rule bases. Various combinations of diagnostic parameters and corresponding to them degrees of acidosis pathology were taken to develop the rule bases. The degree of pathology will vary from “Permanent” to “Acute”, and the linguistic variable will take values from “Min” (the animal is healthy) to “Max” (acute phase).

Significant dependencies of the disease degree from the pH of rumen contents (pH) and Fat content in milk (F) should be determined according to the rules of fuzzy set theory (“If A = B and C = D and ... then m_i = n_j and ...”) and be based on the known data [5–22].

The developed fuzzy production rule bases for inferencing the function $Y_{12} = f(pH, F)$, the function $Y_{34} = f(Pulse\ Rate, Respiratory\ Rate)$, and the resulting function for the Degree of Acidosis Pathology $DAP = f(Y_{12}, Y_{34})$ are presented in Tables 1–3.

Table 1

Rule base for inferencing the function $Y_{12} = f(pH, F)$

Values of the linguistic variable “pH”	Values of the output fuzzy subsets “pH – Fat content, Y ₁₂ ” upon changing the fuzzy function “Fat content, F”				
	Minimum, Min	Low, L	Average, Av	High, H	Maximum, Max
Highest Acidity, HighestAc	Max	Max	H	Av	L
Moderate Acidity, ModAc	Max	H	Av	L	L
Neutral	H	Av	L	Min	Min
Moderate Alkalinity, ModAlk	Av	L	L	Min	Min
Highest Alkalinity, HighestAlk	L	Min	Min	Min	Min

Table 2

Rule base for inferencing the function $Y_{34} = f(PR, RR)$

Values of the linguistic variable “Pulse Rate, PR”	Values of the output fuzzy subsets “Respiration – Pulse, Y ₃₄ ” upon changing the fuzzy function “Respiratory Rate, RR”				
	Minimum, Min	Low, L	Average, Av	High, H	Maximum, Max
Minimum, Min	Min	Min	Min	L	Av
Low, L	L	L	L	Av	H
Average, Av	L	Av	Av	H	Max
High, H	Av	Av	H	Max	Max
Maximum, Max	Av	H	Max	Max	Max

Table 3

Rule base for inferencing the function $DAP = f(Y_{12}, Y_{34}) = f(pH, F, PR, RR)$

Values of the linguistic variable “pH – Fat content, Y ₁₂ ”	Values of the output fuzzy subsets “DAP” upon changing the fuzzy function “Respiration–Pulse, Y ₃₄ ”				
	Minimum, Min	Low, L	Average, Av	High, H	Maximum, Max
Minimum, Min	Min	Min	Min	L	L
Low, L	Min	Min	L	Av	Av
Average, Av	Min	L	Av	H	H
High, H	L	Av	H	H	Max
Maximum, Max	Av	H	Max	Max	Max

2. Synthesis of fuzzy models of the problem. Fuzzy inference operations and synthesis of fuzzy models of the problem were performed using the rule bases. The SciFLT Editor toolbox for Scilab software was used to implement the developed formal formulation of the fuzzy inference problem, which is part of the intelligent system structure⁴. Fuzzy inference for obtaining the resulting membership functions is shown in Fig. 1a–c. In accordance with the fuzzy inference methodology⁵, on the example of the

function $Y_{12} = f(pH, F)$, the operations were performed in the following order:

- 1) fuzzification of problem variables (Fig. 1a–b);
- 2) development of a rule base (Fig. 1c).

After completing fuzzy inference and defuzzification, the resulting functions $Y_{12} = f(pH, F)$; $Y_{34} = f(PR, RR)$ and $DAP = f(Y_{12}, Y_{34})$ were obtained. They are shown graphically in Fig. 2.

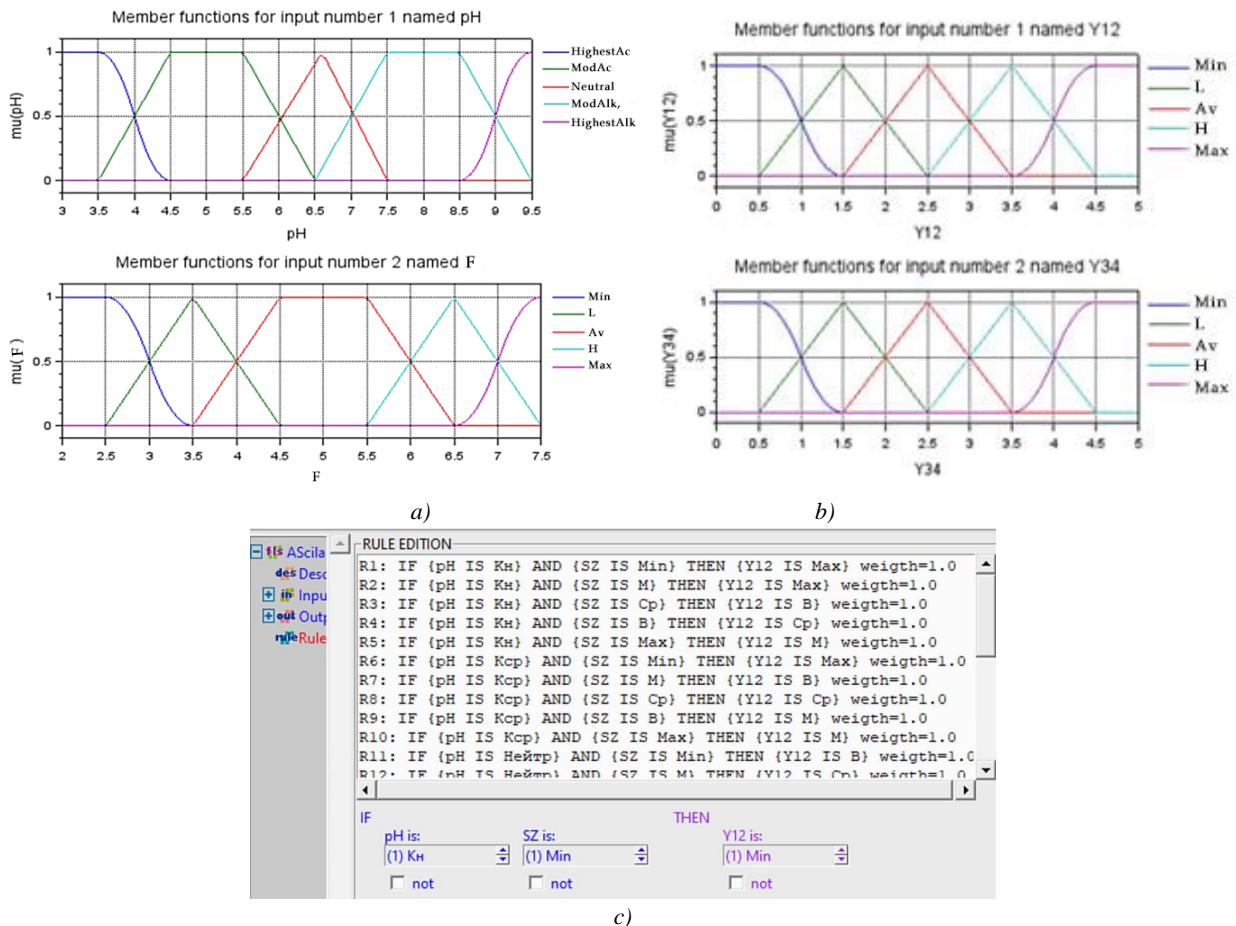

Fig. 1. Fuzzy inference operations by means of SciFLT toolbox: a) pH and F variables; b) Y₁₂ and Y₃₄; c) fuzzy inference rule base for the function $Y_{12} = f(pH, F)$

Note: Russian and Latin symbols in Fig. 1 c) correspond to the English equivalents as follows:

- Кн – HighestAc
- Ксп – ModAc
- Нейтраль – Neutral
- Щщ – ModAlk,
- Щн – HighestAlk
- SZ – F
- Мин – Min
- М – L
- Ср – Av
- В – H

⁴Scilab. URL: <https://www.scilab.org> (accessed: 19.06.2024).

⁵Piegat A. *Fuzzy Modeling and Control: with 96 Tables*. Heidelberg, New York: Physica Publ.; 2001.760 p.

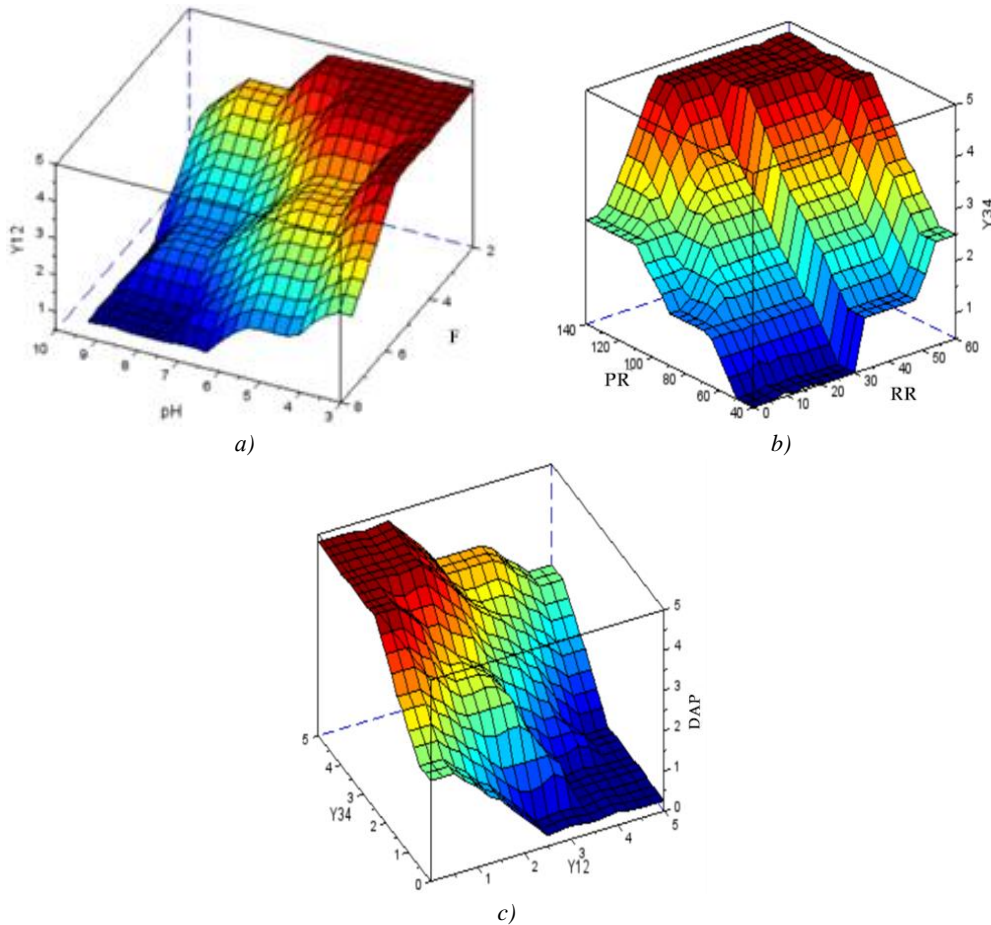

Fig. 2. Resulting functions: *a* — $Y_{12} = f(pH, F)$; *b* — $Y_{34} = f(PR, RR)$; *c* — $DAP = f(Y_{12}, Y_{34})$

3. Development of a generalized model of an intelligent diagnostic system. Figure 3 demonstrates a model of an intelligent system created by means of Xcos toolbox, which uses Constant visual blocks for inputting initial data and Mux multiplexers for generating a data sequence

vector and transmitting data to Controller blocks. These blocks address the corresponding fuzzy systems to obtain fuzzy inference results. The calculation results are displayed on a virtual electronic display.

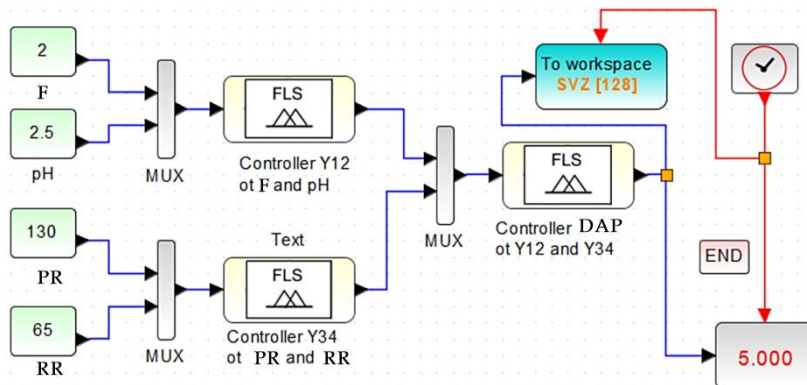

Fig. 3. Model of an intelligent system created by means of Xcos toolbox

4. Computer implementation of the intelligent diagnostic system. To be used in practice, the model requires a user interface. Scilab+Scinotes were used for its development. The main visual interface forms are shown in Figure 4. They provide the information about the program,

documentation, input/output data, and recommendations for treating rumen acidosis depending on its pathology degree.

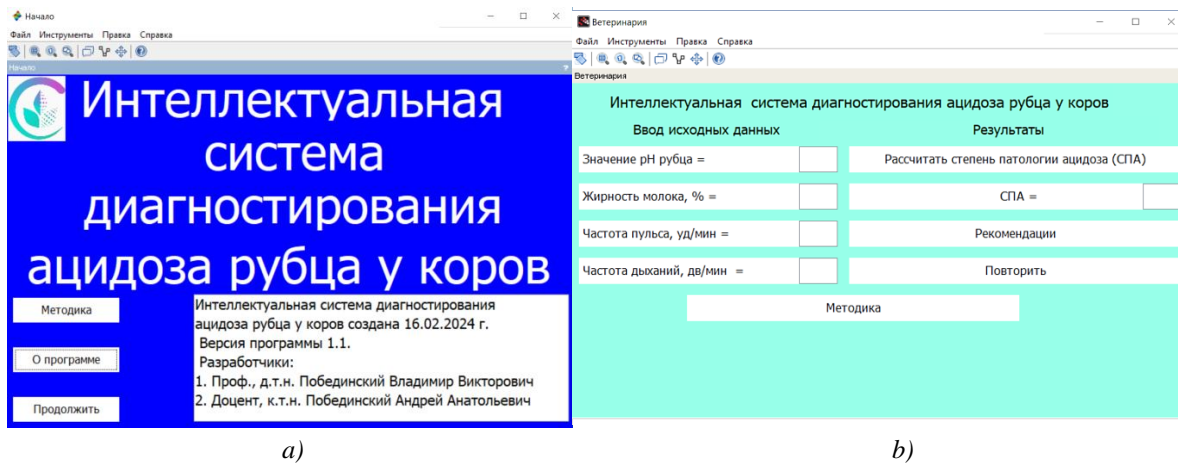

Fig. 4. The main user interface forms of the program: a — home form; b — data input/output and program operation form

Note: Russian texts in Fig. 4 a) correspond to the English equivalents as follows:

Методика – Methodology

О программе – About the program

Продолжить – Continue

Интеллектуальная система диагностирования ацидоза рубца у коров создана 16.02.2024г. Версия программы 1.1. Разработчики:

1. Проф., д.т.н. Побединский Владимир Викторович
 2. Доцент, к.т.н. Побединский Андрей Анатольевич
- An intelligent system for diagnosing rumen acidosis in cows was developed on February 16, 2024. Program version 1.1.

Developers:

1. Vladimir V. Pobedinskiy, Dr.Sci.(Eng.), Prof.
2. Andrey A. Pobedinskiy Cand.Sci.(Eng.), Associate Prof.

Note: Russian texts in Fig. 4 b) correspond to the English equivalents as follows:

Интеллектуальная система диагностирования ацидоза рубца у коров – An intelligent system for diagnosing rumen acidosis in cows

Ввод исходных данных – Input of initial data

Значение pH рубца = pH of rumen contents

Жирность молока, % = Fat content in milk, %

Частота пульса, уд./мин = Pulse Rate, beat/min

Частота дыханий, дв./мин = Respiratory Rate, movements/min

Результаты – Results

Расчитать степень патологии ацидоза (СПА) – Calculate degree of acidosis pathology

СПА = DAP

Рекомендации – Recommendations

Повторить – Repeat

Методика – Methodology

Discussion and Conclusion. The Artificial Intelligence undoubtedly has great potential for development in the agro-industrial complex. The intelligent system for diagnosing rumen acidosis pathology in cows proposed by the authors is innovative and can be implemented into the expert advisory systems, be used for automation of workplaces of the veterinarians and in modern veterinary telemedicine technologies or for other purposes.

The adequate work of the system is an issue of particular importance, due to impossibility to apply the traditional, standard approaches to it. Unlike other models, intelligent rule-based systems, i.e., fuzzy systems and neural networks, get trained throughout their entire existence cycle [23]. This means that upon changing external conditions (e.g., methods of treatment, pharmacological agents, or the occurrence of side effects), new sets of rules will be incorporated into the

fuzzy production rule bases, and the operation of intelligent system will be automatically adjusted. If this procedure is automated by means of software rather than performed manually, the system becomes self-learning.

The standard basic treatment protocols have been inserted as a template into the process of forming treatment recommendations. Possibility for a veterinarian to adjust and clarify the treatment is obligatory foreseen, as the software remains an advisory tool for a veterinarian to make a final decision.

Summing up the study results, it can be concluded that the proposed intelligent system is capable of quite accurate diagnostics of acidosis pathology and is versatile due to its ability to improve the diagnostic process (by adding new rules to the rule bases or adding other diagnostic parameters) without requiring any changes to the program code.

References

1. Amerkhanov HA. *The Role and Place of the Livestock Industry in Ensuring Food Security in the Russian Federation.* (In Russ.) URL: <https://ran-szv.ru/index.php/doklads/amerkhanov-150524> (accessed: 29.01.2026).
2. Samolovov AA. *Rumen Acidosis – The Cause of All Cow Health Problems. Production Disease.* Novosibirsk; 2016. 61 p. (In Russ.).
3. Tregubov VI. *Methods for the Elimination and Prevention of Acidosis in Cows.* (In Russ.) URL: <https://agbz.ru/articles/metody-ustraneniya-i-preduprezhdeniya-atsidoza-u-korov/> (accessed: 11.02.2026).

4. Pobedinskiy VV, Pobedinskiy AA, Iovlev GA. Development of an Intelligent System for Diagnosing Rumen Acidosis in Cows. Part 1: Formalization of Tasks. *Russian Journal of Veterinary Pathology*. 2025;24(4):17–26. (In Russ.). <https://doi.org/10.23947/2949-4826-2025-24-4-17-26>
5. Bakirov B, Ruzikulov NB, Khaitov B, Abdurasulov AKh. Group Prevention of Rumen Acidosis in Cows. *Journal of Osh State University. Agriculture: Agronomy, Veterinary and Zootechnics*. 2023;(4(5)):50–56. (In Russ.). https://doi.org/10.52754/16948696_2023_4_7
6. Vladimirov VE, Kirsanov VV, Pavkin DYU. Study of the Rumen's pH and Temperature for Milk Cows after Calving Acidosis Diagnosis. *Vestnik vs Rossiiskogo nauchno-issledovatel'skogo instituta mekhanizatsii zhivotnovodstva (Bulletin of the All-Russian Research Institute of Animal Husbandry Mechanization)*. 2019;(4(36)):196–199. (In Russ.)
7. Voronov DV, Bober YuN. Indicators pH of the Content of Rumen in the Cows, Patients with Acidosis, with Different Methods of Obtaining the Sample. *Scientific Notes of the Vitebsk State Awarded with the Badge of Honor Academy of Veterinary Medicine*. 2017; 53(3):18–21. (In Russ.)
8. Lugovoi MM, Azarnova TO, Podolnikov VE, Lugovaya IS. Importance of Maintaining a Hydrogen Index in the Cows for Prevention of Metabolic Disorders and for an Increase in Milk Productivity. *Agrarnaya Rossiya (Agrarian Russia)*. 2019;(12):3–7. (In Russ.) <https://doi.org/10.30906/1999-5636-2019-12-3-7>
9. Pavkin DYU, Vladimirov FE. Diagnosis of Subacute Rumen Acidosis in Cows in the Postpartum Period when Using Digital Technologies. *Head of Animal Breeding*. 2020;(12(209)):47–52. (In Russ.)
10. Pobedinsky AA, Pobedinsky VV. A Method for Monitoring Bee Hives and Bee Populations. *Izvestia Orenburg State Agrarian University (Bulletin of the Orenburg State Agrarian University)*. 2023;(6(104)):198–204. (In Russ.)
11. Pobedinsky AA. Remote Monitoring Determining Productivity Laying Hens in a Private Household. *Izvestia Orenburg State Agrarian University (Bulletin of the Orenburg State Agrarian University)*. 2022;(1(93)):127–130. (In Russ.) <https://doi.org/10.37670/2073-0853-2022-93-1-127-130>
12. Ryzhkova GF, Evglevsky AA, Evglevskaya EP, Minenkov NA. The Redistribution of Electrolytes between the Erythrocytes and Plasma of Cows Blood at the Violation of Acid-Base Balance (Acidosis of the Rumen). *Vestnik Kurskoi gosudarstvennoi sel'skokhozyaistvennoi akademii (Bulletin of Kursk State Agricultural Academy)*. 2018;(4):136–139. (In Russ.)
13. Elenshleger AA, Solovyeva VV. Clinical and Morphological Blood Parameters in Rumen Acidosis in Dairy Cows. *Bulletin of Altai State Agricultural University*. 2016;(6(140)):112–115. (In Russ.)
14. Abarghuei MJ, Rouzbehan Y, Salem AZM, Zamiri MJ. Nutrient Digestion, Ruminal Fermentation and Performance of Dairy Cows Fed Pomegranate Peel Extract. *Livestock Science*. 2013;157(2–3):452–461.
15. AlZahal O, Kebreab E, France J, Froetschel M, McBride BW. Ruminal Temperature May Aid in the Detection of Subacute Ruminal Acidosis. *Journal of Dairy Science*. 2008;91(1):202–207. <https://doi.org/10.3168/jds.2007-0535>
16. Antanaitis R, Juozaitiene V, Malasauskiene D, Televicius M., Urbutis M. Biomarkers from Automatic Milking System as an Indicator of Subclinical Acidosis and Subclinical Ketosis in Fresh Dairy Cows. *Polish Journal of Veterinary Science*. 2019;22(4):685–693. <https://doi.org/10.24425/pjvs.2019.129981>
17. Asqarov SS, Yunusov XB, Roziqulov NB. Qo'zilar Dispepsiyasining Klinik Belgilari va Ularning Etiopatogenetik Asoslari. *Veterinariya meditsinasi*. 2023;8:18-19.
18. Smith BP, Van Metre DC, Pusterla N (Eds). *Large Animal Internal Medicine*. 6th Edition. USA: Elsevier; 2020. 1874. <https://doi.org/10.1016/C2016-0-01788-6>
19. Chen L, Liu Sh, Wang H, Wang M, Lihuai Yu. Relative Significances of pH and Substrate Starch Level to Roles of Streptococcus Bovis S1 in Rumen Acidosis. *AMB Express*. 2016;6(1):80. <https://doi.org/10.1186/s13568-016-0248-2>
20. Chen L, Luo Y, Wang H, Liu Sh, Shen Y, Wang M. Effects of Glucose and Starch on Lactate Production by Newly Isolated Streptococcus Bovis S1 from Saanen Goats. *Applied and Environmental Microbiology*. 2016;82(19):5982–5989. <https://doi.org/10.1128/AEM.01994-16>
21. Millen DD, De Arrigoni MB, Pacheco RDL (Eds). *Rumenology*. Cham: Springer; 2016. 314 p. <https://doi.org/10.1007/978-3-319-30533-2>
22. McSweeney CS, Mackie RI (Eds). *Improving Rumen Function: Burleigh Dodds Series in Agricultural Science*. Cambridge: Burleigh Dodds Science Publishing; 2020. 862 p.
23. *The Era of Self-Learning: How Self-Learning AI is Transforming Industries*. URL: <https://rfidunion.com/ru/information/self-learning-ai-will-create-a-new-self-era.html> (accessed: 11.02.2026)

About the Authors:

Vladimir V. Pobedinskiy, Professor, Dr.Sci. (Engineering), Head of the Management in Technical Systems and Innovative Technologies Department, Ural State Forest Engineering University (Ekaterinburg, Russia); Professor of the Service of Transport and Technological Machines and Equipment for the Agro-Industrial Complex Department, Ural State Agrarian University (Ekaterinburg, Russia), [SPIN-code](#), [ORCID](#), [Researcher ID](#), [Scopus ID](#), pobedinskyvv@mail.ru

Andrey A. Pobedinskiy, Associate Professor of the Forestry, Woodworking and Applied Mechanics Department, Agrarian Institute of Tyumen State University (18, Roshchinskoye Shosse, Tyumen, 625003, Russian Federation), [SPIN-code](#), [ORCID](#), [Researcher ID](#), vm993711@mail.ru

Grigory A. Iovlev, Cand.Sci. (Economics), Head of the Service of Transport and Technological Machines and Equipment for Agro-Industrial Complex Department, Ural State Agrarian University (Ekaterinburg, Russian Federation), [SPIN-code](#), [ORCID](#), [Researcher ID](#), [Scopus ID](#), gri-iovlev@yandex.ru

Claimed Contributorship:

VV Pobedinskiy: scientific supervision, formulating the main concept, aim and objectives of the research, development of a model and intelligent system software, preparing the text, formulating conclusions.

AA Pobedinskiy: justification of diagnostic parameters for an intelligent system, analysis of research results, correcting conclusions.

GA Iovlev: formatting and finalizing the text.

Conflict of Interest Statement: the authors declare no conflict of interest.

All authors have read and approved the final manuscript.

Об авторах:

Владимир Викторович Побединский, профессор, доктор технических наук, заведующий кафедрой управления в технических системах и инновационных технологий Уральского государственного лесотехнического университета (620100, Российская Федерация, г. Екатеринбург, Сибирский тракт, 37); профессор кафедры сервиса транспортных и технологических машин и оборудования АПК Уральского государственного аграрного университета (620000, Российская Федерация, г. Екатеринбург, ул. Карла Либкнехта, стр. 42), [SPIN-код](#), [ORCID](#), [Researcher ID](#), [Scopus ID](#), pobedinskyvv@mail.ru

Андрей Анатольевич Побединский, доцент кафедры лесного хозяйства, деревообработки и прикладной механики Аграрного института Тюменского государственного университета (625003, Российская Федерация, г. Тюмень, ул. Рошинское шоссе, 18), [SPIN-код](#), [ORCID](#), [Researcher ID](#), vm993711@mail.ru

Григорий Александрович Иовлев, кандидат экономических наук, заведующий кафедрой сервиса транспортных и технологических машин и оборудования АПК Уральского государственного аграрного университета (620000, Российская Федерация, г. Екатеринбург, ул. Карла Либкнехта, стр. 42), [SPIN-код](#), [ORCID](#), [Researcher ID](#), [Scopus ID](#), gri-iovlev@yandex.ru

Заявленный вклад авторов:

В.В. Побединский: научное руководство, формирование основной концепции, цели и задач исследования, разработка модели и программы интеллектуальной системы, подготовка текста, формирование выводов.

А.А. Побединский: обоснование диагностических параметров для интеллектуальной системы, анализ результатов исследований, корректировка выводов.

Г.А. Иовлев: оформление и доработка текста.

Конфликт интересов: авторы заявляют об отсутствии конфликта интересов.

Все авторы прочитали и одобрили окончательный вариант рукописи.

Received / Поступила в редакцию 25.11.2025

Reviewed / Поступила после рецензирования 24.12.2025

Accepted / Принята к публикации 27.12.2025

ANIMAL PATHOLOGY, MORPHOLOGY, PHYSIOLOGY,
PHARMACOLOGY AND TOXICOLOGY
ПАТОЛОГИЯ ЖИВОТНЫХ, МОРФОЛОГИЯ, ФИЗИОЛОГИЯ,
ФАРМАКОЛОГИЯ И ТОКСИКОЛОГИЯ



UDC 619:616.126.4-07:636.7

Original Empirical Research

<https://doi.org/10.23947/2949-4826-2026-25-1-34-40>

A Clinical Case of Proliferative and Necrotizing Otitis Externa (PNOE) in an Elderly Cat



EDN: TSAVDS

Anastasia Yu. Kochetkova , Anna S. Fomina ✉

Don State Technical University, Rostov-on-Don, Russian Federation

✉ a_bogun@mail.ru

Abstract

Introduction. A clinical case of proliferative and necrotizing otitis externa (PNOE) in an elderly cat has been described, i.e. diagnostics and treatment with tacrolimus. This syndrome of unknown etiology occurs in cats aged from 2 months to 12 years. It bilaterally affects the concave pinnae and the external acoustic pore. Disease development in the ear canal is accompanied with the secondary bacterial or *Malassezia* otitides. Fifteen foreign studies investigating PNOE in cats and dogs published in the period of 2000–2025 have been reviewed.

Materials and Methods. In November 2024, the owners of a five-year-old cat attended to the veterinary clinic “Center” (Rostov-on-Don) with the complaint on frequent otitides in their pet. PNOE diagnosis was based on the animal’s medical history, clinical examination, microscopic and cytological examination of discharge from ears (performed in the “Vet Union” veterinary laboratory, Moscow). Treatment included topical application of 0.1% tacrolimus ointment.

Results. Examination of the inner surface of the auricles revealed stenosis of the external ear canals and a significant number of black, dry crusts. An ear culture test revealed secondary microbial contamination with *Pseudomonas aeruginosa*, *Klebsiella oxytoca*, and *Enterobacter cloacae*; whereas, *Candida* or *Malassezia spp* fungi were not isolated. Also, during microscopy of earwax, no mites of the genus *Otodectes cynotis* were isolated. After 4 weeks of treatment with 10 g of 0.1% tacrolimus ointment applied topically, normalization of condition was noticed during the otoscopic examination of the auricles.

Discussion and Conclusion. The efficiency of treating PNOE in cats with tacrolimus ointment applied topically to the auricle crusts has been proved. The data and photographs presented in the article may be useful for practicing veterinarians for diagnostics and treatment of this relatively rare disease.

Keywords: clinical case, cats, proliferative and necrotizing otitis externa, PNOE, tacrolimus

Informed consent: The owner’s consent for publication has been obtained.

Sources of Funding: The study was carried out at the owner’s expense.

For Citation. Kochetkova AY, Fomina AS. A Clinical Case of Proliferative and Necrotizing Otitis Externa (PNOE) in an Elderly Cat. *Russian Journal of Veterinary Pathology*. 2026;25(1):34–40. <https://doi.org/10.23947/2949-4826-2026-25-1-34-40>

Клинический случай пролиферативного и некротизирующего наружного отита (PNOE) у возрастной кошки

Кочеткова А.Ю. , Фомина А.С.  

Донской государственный технический университет, г. Ростов-на-Дону, Российская Федерация

 a_bogun@mail.ru

Аннотация

Введение. Описан клинический случай пролиферативного и некротизирующего наружного отита (PNOE) у взрослой кошки — диагностика и лечение с применением такролимуса. Данный синдром неизвестной этиологии возникает у кошек в возрасте от 2 месяцев до 12 лет: билатерально поражается вогнутая часть ушной раковины и наружное слуховое отверстие; распространение заболевания по слуховому проходу сопровождается вторичными бактериальными или малассезиозными отитами. Рассмотрены 15 зарубежных исследований пролиферативного и некротизирующего наружного отита у кошек и собак, опубликованных в 2000–2025 гг.

Материалы и методы. В ноябре 2024 г. в ветеринарную клинику «Центр» (г. Ростов-на-Дону) обратились владельцы пятилетней кошки с жалобой на частые отиты у животного. Диагностика PNOE была основана на данных анамнеза, клинического осмотра, микроскопического и цитологического исследования содержимого ушного канала (ветеринарная лаборатория Vet Union, г. Москва). Терапия проводилась с применением 0,1% мази такролимуса наружно.

Результаты исследования. При осмотре на внутренней поверхности ушных раковин был обнаружен стеноз наружных слуховых проходов, значительное количество черных и сухих корочек. При посеве материала из слухового прохода на микрофлору выявлено вторичное микробное обсеменение (*Pseudomonas aeruginosa*, *Klebsiella oxytoca* и *Enterobacter cloacae*); при этом грибков рода *Candidaspp* и *Malasseziaspp* не выявлено. При микроскопическом анализе ушной серы клещей рода *Otodectes cynotis* также не выявлено. После проведения терапии с применением 10 г 0,1% мази такролимуса наружно через 4 недели при отоскопическом исследовании ушных раковин отмечена нормализация состояния.

Обсуждение и заключение. Доказана эффективность лечения PNOE у кошек с применением такролимуса наружно на корочки ушных раковин топикально. Представленные в статье данные и фотоматериалы могут быть полезными для практикующего ветеринарного врача при диагностике и лечении заболевания, регистрируемого достаточно редко.

Ключевые слова: клинический случай, кошки, пролиферативный и некротизирующий наружный отит, PNOE, такролимус

Информационное согласие: Получено согласие владельца на публикацию.

Источники финансирования: Исследование проведено за счёт владельца.

Для цитирования. Кочеткова А.Ю., Фомина А.С. Клинический случай пролиферативного и некротизирующего наружного отита (PNOE) у возрастной кошки. *Ветеринарная патология.* 2026;25(1):34–40. <https://doi.org/10.23947/2949-4826-2026-25-1-34-40>

Introduction. Proliferative and necrotizing otitis externa (PNOE) in cats is a syndrome of unknown etiology [1] that is quite rare. By 2025, 21 cases of PNOE had been reported in the literature [2]. Proliferative and necrotizing otitis in kittens was first described in [1, 3]. Initially, it was believed that only kittens under 1 year old were susceptible to the disease, but it has now been established that PNOE occurs in cats aged of 2 months to 12 years, and, most often the disease is being recorded by the age of 4 years [3–6]. Breed susceptibility has not been revealed, however, sex-based susceptibility is being recorded—out of 22 cases, 16 were recorded in male cats [6].

The etiology of the disease is unclear, although its relation to the immune system is assumed [1, 7]. This assumption is supported by the possibility of PNOE treatment with topical and systemic immunomodulators [2]. This is likely due to T-cell-induced caspase-positive apoptosis of epidermal keratinocytes, which has features common with such diseases as erythema multiforme [5]. So far, the infectious agents, including that of feline viral diseases, have not been associated with this disease; their involvement in its occurrence has not been proven [6]. The authors [1, 3] describe a similar case of otitis in a kitten with the histopathological features, immunohisto-

chemical staining results, and response to treatment consistent with keratinocyte apoptosis induced by skin-infiltrating T-cells.

Most often, PNOE bilaterally and symmetrically affects the concave pinna and the external acoustic pore, but can also develop along the ear canal and cause secondary bacterial or *Malassezia* otitides, accompanied by crusting and purulent discharge [3, 5–8]. Lesions are attributed with erythematous plaques with hyperkeratotic crusts tight to the pinna. Crusts are most often golden to dark brown in colour, indicating severe hyperkeratosis and parakeratosis [8]. In case of trauma, ulcers with some haemorrhages are observed. Characteristic lesions can also localize in the cat muzzle, in the periocular or perioral regions. Generalized lesions, which get spontaneously healed, are also reported in some publications [1, 5, 6].

The main changes observed during histopathological examination of skin biopsies in cats with PNOE were epidermal and follicular hyperplasia. This lesion underlies the term used to describe the disease, namely, the proliferative otitis [1, 5, 6]. Necrotic changes, which underlie the second term used to describe the disease, are less pronounced, and dyskeratosis is rarely observed. The histopathological analysis revealed the differences between otitis and dyskeratosis which mainly referred to dyskeratoses. The initial diagnosis would be an adverse reaction to topical medications; however, satellite cell apoptosis and fewer hyperplastic changes could be expected in this condition [3].

As reported in [9], treatment of PNOE variants, such as additional auricular dermatitis and middle ear lesions, with systemic immunosuppressants proves to be efficient: a sick cat responded favourably to treatment with cyclosporine, systemic prednisolone, and topical tacrolimus. In publication [10], two clinical cases of the successful use of oclacitinib in treatment of cats with PNOE were noted, when standard therapy with tacrolimus didn't result in the expected response. Oclacitinib is an inhibitor of Janus kinase-1 (JAK1), which affects the signaling pathways of cytokines participating in the development of pruritus and allergic dermatitis [11]. Although the use of oclacitinib is not recommended in cats, some publications indicate that this drug may have a therapeutic effect in various immune-mediated and autoimmune diseases in dogs and cats [3, 4, 12, 13].

Otitis externa is relatively rare reported in cats compared to dogs and is most often associated with ear mite infestations, inflammatory polyps, ear canal neoplasia, and associated allergic conditions.

The present article describes a clinical case of proliferative and necrotizing otitis externa in an elderly cat, the diagnosis and efficient treatment thereof with tacrolimus.

Materials and Methods. A five-year-old spayed Scottish Fold cat was admitted to the veterinary clinic “Center” (Rostov-on-Don) in November 2024 with atypical proliferative lesions in both ear canals. According to the owners, the animal had been suffering from recurrent otitis for two

years. The cat was kept in an apartment; the owners did not own any other pets.

PNOE was diagnosed based on the patient's medical history, clinical examination, and microscopic and cytological examinations of the ear canal discharge. Two samples were collected from each pinna for laboratory testing: one for microscopy (to exclude *Otodectes cynotis*) at $\times 10$ magnification (Olympus CX23 microscope, Japan); another for cytological examination. A swab sample was fixed, stained with “Di-ahim-Diff-Quick” dye (“ABRIS+” Research and Production Company, Russia), and examined using the same microscope at $\times 100$ magnification. Otoscopy was performed using a light otoscope (Welch Allyn Inc., USA).

Microbiological testing was performed at the “Vet Union” laboratory (Moscow). Earwax microscopy was performed in the laboratory of the clinic using an Olympus CX23 microscope at $\times 10$ magnification.

The ear culture test, antibiotic sensitivity test, and fungal culture test for *Candida spp.* and *Malassezia spp.* were also performed at the “Vet Union” veterinary laboratory.

Treatment included topical application of 0.1% tacrolimus ointment (Protopic, Astellas Pharma, Japan).

A general examination 4 weeks after treatment was performed using a Welch Allyn light otoscope.

Research Results. According to the medical history, in the previous months, the cat had been treated with numerous topical medications against ear parasites, yeast, and bacterial infections that included compound drops containing 5% Baytril and dexamethasone. The cat systematically received a single topical application of selamectin (Stronghold, manufactured by Zoetis (formerly Pfizer Animal Health), USA) and amoxicillin + clavulanic acid (Krka, Slovenia) at a dose of 15 mg/kg twice a day for 14 days.

The ear culture test and antibiotic sensitivity test, revealed the following microorganisms: *Pseudomonas aeruginosa*, *Klebsiella oxytoca*, and *Enterobacter cloacae* (Fig. 1). The results of microbiological analysis proved to be characteristic not of an infection, but of the secondary microbial contamination. The fungal culture test for fungi of the genus *Candida spp.* and *Malassezia spp.* did not reveal any fungi (Fig. 2).

A general examination revealed no other skin lesions. Bilateral lesions were found on the inner surface of the pinnae. Stenosis of the external ear canals and a significant number of black, dry crusts were also detected. Minor bleeding was noted during trauma and diagnostic testing (Fig. 3). An otoscopic examination could not be performed during first consultation due to stenosis of the ear canals. Examination of the nasopharynx revealed no anatomical or pathological changes.

Initially, the following differential diagnoses were considered: otoacariasis (parasitic otitis), which might have not been healed with a single application of spot-on drops, and chronic bacterial or yeast otitis externa secondary to otitis media (or, less likely, to bilateral ear polyps).

Ear culture test (discharge from external ear canal)

- 1 Pseudomonas aeruginosa 10⁷ SFU/swab
- 2 Klebsiella oxytoca 10⁷ SFU/swab
- 3 Enterobacter cloacae 10⁷ SFU/swab

Sensitivity to medications	1	2	3
AMPICILLIN		R	R
AMOXICILLINE CLAVULANAT		S	R
CO-TRIMOXAZOL	R		
CEFOTAXIME	R	S	S
CEFTAZIDIME		S	S
CEFTRIAxon	R	S	S
CEFEPIME	R	S	S
GENTAMICIN	S		
AMIKACIN	S		
ENROFLOXACIN	S	S	S

Comments

S – Susceptible

R – Resistant

I – Intermediate resistant

Comments to the lab test application

Localization: discharge from external ear canal

Test results are not a diagnosis; a consultation with a specialist is required.

Fig. 1. Results of ear culture test and antibiotic sensitivity test

The fungal culture test for fungi of the genus *Candida* spp. and *Malassezia* spp. and Antimycogram

- 1. *Candida* spp. growth is not detected
- 2. *Malassezia* spp growth is not detected

Fig. 2. Results of ear fungal culture test for fungi of the genus *Candida* spp. and *Malassezia* spp.



Fig. 3. Proliferative and necrotizing otitis in a cat before treatment

The earwax microscopy for the presence of *Otodectes cynotis* mites was negative, and cytological examination identified only keratinocytes (Fig. 4).

Treatment began with topical application of 10 g of 0.1% Protopic ointment to the auricular crusts. After three days of treatment, the condition of the pinnae improved significantly (Fig. 5).

The cat was re-examined after 4 weeks of therapy. Otoloscopic examination revealed both the ear canal and pinnae to be in normal condition. A small amount of earwax still obscured the tympanic membrane on the left side, whereas the tympanic membrane on the right side was normally visible (Fig. 6). Cytological examination of the earwax revealed only keratinocytes.

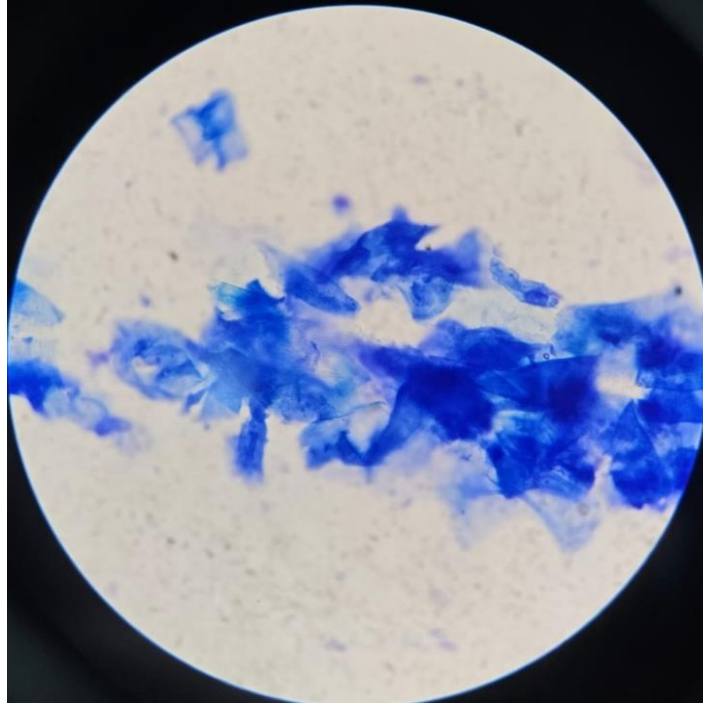

Fig. 4. Cytology of the swab sample from a cat with PNOE. Microscopy presents keratinocytes +++ . Staining with “Diahim-Diff-Quick”. Magnification $\times 100$.



Fig. 5. View of the pinna after three days of using Protopic ointment

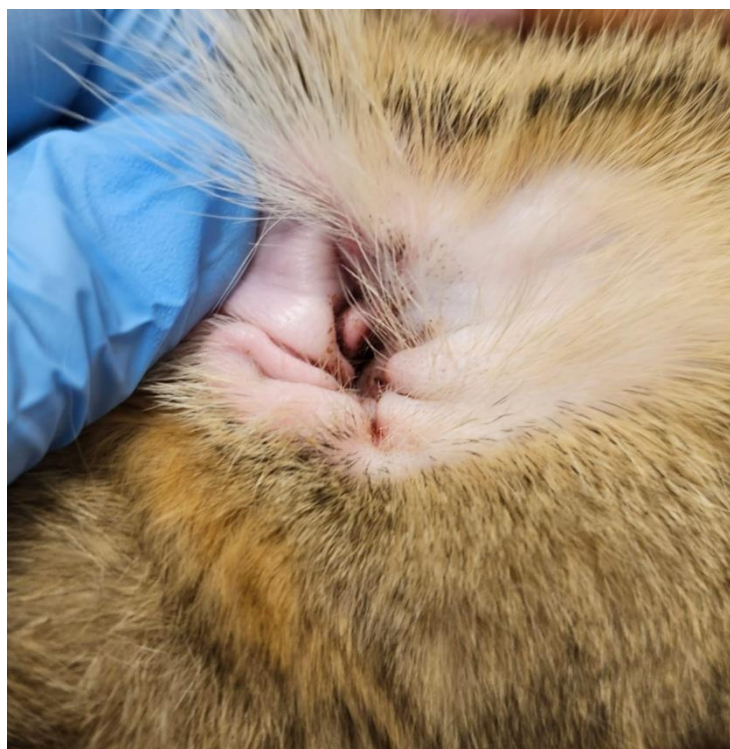

Fig. 6. Condition of the pinna in dynamics after 4 weeks of therapy

Discussion and Conclusion. If possible, the otoscopic examination to evaluate the condition of external acoustic pore and the integrity of the tympanic membranes should always be performed in animals with otitis externa [14, 15]. Otoscopy or video otoscopy allows a veterinarian to diagnose and prognosticate this disease. However, in cats with proliferative and necrotizing otitis externa, an otoscopic examination is not always possible due to the large number of crusts that accumulate in the ear canals. Pruritus may or may not be present, but secondary bacterial or yeast otitides externa are always present [1, 5]. In our case, the pinnae were not affected, and lesions similar to that discussed above affected only the external ear canals.

Based on the achieved treatment results and data obtained from the available literature, the efficacy of tacrolimus for treatment of PNOE in cats could be ascertained. Tacrolimus is sold in the form of ointment, which can be difficult to apply deep into the ear canals. Therefore, owners are advised to apply the ointment topically to the pinnae, wearing gloves first. Side effects that might occur after topical use of tacrolimus include burning or pruritus. The data and photographs presented in the present article may be useful for practicing veterinarians in diagnosing and treating this relatively rare disease.

References

1. Mauldin EA, Ness TA, Goldschmidt MH. Proliferative and Necrotizing Otitis Externa in Four Cats. *Veterinary Dermatology*. 2007;18(5):370–377. <https://doi.org/10.1111/j.1365-3164.2007.00614.x>
2. Brame BE. Proliferative and Necrotizing Otitis Externa of Cats and Kittens. *Veterinary Clinics of North America: Small Animal Practice*. 2025;55(2):337–361. <https://doi.org/10.1016/j.cvsm.2024.11.012>
3. Gross TL, Ihrke P, Walder E, Affolter VK. Necrotizing Diseases of the Epidermis. In: *Skin Diseases of the Dog and Cat, Clinical and Histopathologic Diagnosis*. Blackwell Publishing, 2005. P. 75–104. <https://doi.org/10.1111/j.1748-5827.2008.00573.x>
4. Carrasco I, Martinez M, Albinyana G. Beneficial Effect of Oclacitinib in a Case of Feline Pemphigus Foliaceus. *Veterinary Dermatology*. 2021;32:299–301. <https://doi.org/10.1111/vde.12949>
5. Vidémont E, Pin D. Proliferative and Necrotising Otitis in a Kitten: First Demonstration of T-Cell-Mediated Apoptosis. *Journal of Small Animal Practice*. 2010;51:599–603. <https://doi.org/10.1111/j.1748-5827.2010.00999.x>
6. Yager J. Feline Lymphocytic Non-Neoplastic Dermatoses. In: *Proceedings of the European Society Veterinary Dermatology Congress*. Slovenia, Bled; 2009.
7. Borio S, Massari F, Abramo F, Colombo S. Proliferative and Necrotising Otitis Externa in a Cat Without Pinnal Involvement: Video-Otoscopic Features. *Journal of Feline Medicine Surgery*. 2013;15(4):353–356. <https://doi.org/10.1177/1098612x12468838>

8. Stevens BJ, Linder KE. Pathology in Practice. Proliferative and Necrotizing Otitis Externa. *Journal of American Veterinary Medical Association*. 2012;241(5):567–569. <https://doi.org/10.2460/javma.241.5.567>
9. Panzuti P, Jongh O, Dony M, Vial S, Mosca M, Pin D. Extra-Auricular Lesions of Proliferative and Necrotizing Otitis Externa in Three Kittens. *Veterinary Dermatology*. 2021;32(4):385–e110. <https://doi.org/10.1111/vde.12968>
10. Chan T, Koch SN, Devine S, Mendoza-Kuznetsova E. Oclacitinib Therapy in Two Cats with Refractory Proliferative and Necrotizing Otitis Externa. *Veterinary Dermatology*. 2024;35(5):568–572. <https://doi.org/10.1111/vde.13269>
11. Gonzales AJ, Bowman JW, Fici GJ, Zhang M, Mann DW, Mitton-Fry M. Oclacitinib (APOQUEL®) is a novel Janus kinase inhibitor with activity against cytokines involved in allergy. *Journal of Veterinary Pharmacology and Therapeutics*. 2014;37(4):317–324. <https://doi.org/10.1111/vde.13269>
12. Harvey RG, Olivri A, Lima T, Olivry T. Effective Treatment of Canine Chronic Cutaneous Lupus Erythematosus Variants with Oclacitinib: Seven Cases. *Veterinary Dermatology*. 2023;34(1):53–58. <https://doi.org/10.1111/vde.13128>
13. High EJ, Linder KE, Mamo LB, Levy BJ, Herrmann I, Bizikova P. Rapid response of hyperkeratotic erythema multiforme to oclacitinib in two dogs. *Veterinary Dermatology*. 2020;31(4):330–e86. <https://doi.org/10.1111/vde.12852>
14. Angus JC, Campbell KL. Uses and Indications for Video-Otoscopy in Small Animal Practice. *Veterinary Clinics of North America: Small Animal Practice*. 2001;31(4):809–828. [https://doi.org/10.1016/s0195-5616\(01\)50072-8](https://doi.org/10.1016/s0195-5616(01)50072-8)
15. Cole LK. Otoscopic Evaluation of the Ear Canal. *Veterinary Clinics of North America: Small Animal Practice*. 2004;34:397–410. <https://doi.org/10.1016/j.cvsm.2003.10.004>

About the Authors:

Anastasia Yu. Kochetkova, Cand.Sci. (Biology), Associate Professor of the Biology and General Pathology Department, Don State Technical University (1, Gagarin Sq., Rostov-on-Don, 344003, Russian Federation), [SPIN-code](#), [ORCID](#), [Researcher ID](#), [Scopus ID](#), lastik61@yandex.ru

Anna S. Fomina, Cand.Sci.(Biology), Associate Professor of the Biology and General Pathology Department, Don State Technical University (1, Gagarin Sq., Rostov-on-Don, 344003, Russian Federation), [SPIN-code](#), [ORCID](#), [Researcher ID](#), [Scopus ID](#), a_bogun@mail.ru

Claimed Contributorship:

AYu Kochetkova: formulating the main concept, aims and objectives of the research, preparing a review of modern publications, conducting the research, preparing the text.

AS Fomina: preparing a review of modern publications, preparing the text

Conflict of Interest Statement: the authors declare no conflict of interest.

All authors have read and approved the final manuscript.

Об авторах:

Анастасия Юрьевна Кочеткова, кандидат биологических наук, доцент кафедры «Биология и общая патология» Донского государственного технического университета (344003, Российская Федерация, г. Ростов-на-Дону, пл. Гагарина, 1), [SPIN-код](#), [ORCID](#), [Researcher ID](#), [Scopus ID](#), lastik61@yandex.ru

Анна Сергеевна Фомина, кандидат биологических наук, доцент кафедры «Биология и общая патология» Донского государственного технического университета, (344003, Российская Федерация, г. Ростов-на-Дону, пл. Гагарина, 1), [SPIN-код](#), [ORCID](#), [Researcher ID](#), [Scopus ID](#), a_bogun@mail.ru

Заявленный вклад авторов:

А.Ю. Кочеткова: формирование основной концепции, цель и задачи исследования, подготовка обзора современных исследований, проведение исследования, подготовка текста.

А.С. Фомина: подготовка обзора современных исследований, подготовка текста.

Конфликт интересов: авторы заявляют об отсутствии конфликта интересов.

Все авторы прочитали и одобрили окончательный вариант рукописи

Received / Поступила в редакцию 24.12.2025

Reviewed / Поступила после рецензирования 20.01.2026

Accepted / Принята к публикации 23.01.2026

ANIMAL BREEDING, SELECTION, GENETICS, AND BIOTECHNOLOGY

РАЗВЕДЕНИЕ, СЕЛЕКЦИЯ, ГЕНЕТИКА И БИОТЕХНОЛОГИЯ ЖИВОТНЫХ



UDC:619:636.2:575.174.4

Original Empirical Research

<https://doi.org/10.23947/2949-4826-2026-25-1-41-49>

EDN: TSFAPY

Finding Associations of Single Nucleotide Polymorphisms with Exterior Traits (Pelvic Parameters) in Holstein CowsMaksim V. Bytov , Vladlena D. Zubareva , Alexander S. Krasnoperov ,Natalia A. Bezborodova , Marina A. Pechenkina , Olga V. Sokolova

Ural Federal Agrarian Research Center of the Ural Branch of the Russian Academy of Sciences, Ekaterinburg, Russian Federation

✉ bytovmaks@mail.ru**Abstract**

Introduction. Exterior traits of a cow can have crucial effect on development of pathological conditions, for example, sacrum anatomy features can be related to the risk of dystocia (pathological or difficult parturition). In dairy farming, pelvic parameters are one of the key factors enabling control of easy calving. However, modern breeding focuses on selection of the herd individuals with the highest milk yield and long-term economic productivity, whereas the exterior traits, unfortunately, are taken into account to a lesser extent. The aim of the present research is to identify associations of single-nucleotide polymorphisms with cow pelvic exterior parameters that are important prerequisites of susceptibility to easy or difficult calving. As a result, it will be possible to determine the genetic markers to be included into the selection-breeding programs.

Materials and Methods. The study was conducted at Ural Research Veterinary Institute — a structural division of Ural Federal Agrarian Research Center of the Ural Branch of the Russian Academy of Sciences in the period from 2023 to 2025. The exterior trait inheritance patterns were studied in Holstein cows (n=155) across three pelvic dimensions: sacrum height, hip width, and ischial tuberosity width. Association tests were conducted using SNPAssoc R package.

Results. The mean values and standard deviations for pelvic height at sacrum in cows were found to be 161.7±5.3 cm; for width at hips — 41.1±3.9 cm; for width at ischial tuberosities — 22.4±2.1 cm. For each individual, genotyping with 13 polymorphisms was performed. Rs109452259 polymorphism in C* allele was revealed to have negative effect on hip width in Holstein cows. Rs134055603 and rs43038601 polymorphisms in G/G and C/A genotypes respectively, were established to have putative epistatic interaction with positive effect on the sacrum height. Also, rs134055603 and rs137396952 polymorphisms in C/A and C/C genotypes respectively were found to have possibly synergistic effect.

Discussion and Conclusion. The data obtained in the frame of the study are reliable for the observed-level statistical interaction. Potential limitations of the study include possible influence of the unaccounted confounding factors, such as variability of animals within the studied groups by age, live body weight, lactation number, etc. For confirmation of the biological mechanisms, further functional studies are required.

Keywords: cows, Holstein breed, exterior traits, sacrum height, hip width, ischial tuberosity width, polymorphisms, genetic associations, selection-breeding

Funding. The research was conducted in the frame of the State Assignment of the Ministry of Science and Higher Education of the Russian Federation No. 0532-2025-0003 “Development of High-Precision Methods for Identifying Genetic Determinants of Disease Resistance for Use in Cattle Breeding”.

For Citation. Bytov MV, Zubareva VD, Krasnoperov AS, Bezborodova NA, Pechenkina MA, Sokolova OV. Finding Associations of Single Nucleotide Polymorphisms with Exterior Traits (Pelvic Parameters) in Holstein Cows. *Russian Journal of Veterinary Pathology*. 2026;25(1):41–49. <https://doi.org/10.23947/2949-4826-2026-25-1-41-49>

Поиск ассоциаций однонуклеотидных полиморфизмов с показателями экстерьера (тазовые параметры) коров голштинской породы

М.В. Бытов  , В.Д. Зубарева , А.С. Краснощёров , Н.А. Безбородова , М.А. Печёнкина ,
О.В. Соколова

Уральский федеральный аграрный научно-исследовательский центр Уральского отделения Российской академии наук,
г. Екатеринбург, Российская Федерация

 bytovmaks@mail.ru

Аннотация

Введение. Экстерьерные параметры коровы могут иметь решающее значение в развитии патологического состояния, например, особенности строения крестца могут быть связаны с риском дистоции (патологические или трудные роды). Параметры таза являются одним из ключевых факторов управления легкостью отела в молочном скотоводстве, однако современная селекция направлена на закрепление в стаде особей с наибольшей молочной продуктивностью и длительным хозяйственным использованием, и экстерьерные параметры, к сожалению, учитываются в меньшей степени. Цель исследования — выявить ассоциации однонуклеотидных полиморфизмов с экстерьерными показателями таза коров, играющими важную роль в предрасположенности к легкому или трудному отелу, что позволит определить генетические маркеры для использования в селекционных программах.

Материалы и методы. Исследование проведено в Уральском НИВИ — структурном подразделении ФГБНУ УрФАНИЦ УрО РАН в период с 2023 по 2025 гг. Исследованы модели наследования экстерьерных параметров по трем проекциям таза коров голштинской породы (n=155): высота в крестце, ширина в маклоках, ширина в седалищных буграх. Ассоциативные тесты проведены с использованием SNPAssoc для программной среды R.

Результаты исследования. Установлено, что средние значения и стандартные отклонения для высоты таза коров в крестце равны 161,7±5,3 см; для ширины в маклоках — 41,1±3,9 см; для ширины в седалищных буграх — 22,4±2,1 см. Проведено генотипирование каждой особи по 13 полиморфизмам. Для коров голштинской породы по rs109452259 выявлен отрицательный эффект аллеля C* на ширину в маклоках. Обнаружено предположительно эпистатическое взаимодействие для rs134055603 и rs43038601 для генотипов G/G и C/A, соответственно, с положительным эффектом на высоту в крестце. Также обнаружено эпистатическое взаимодействие для rs134055603 и rs137396952, вероятно, с синергическим характером для генотипа C/A и C/C соответственно.

Обсуждение и заключение. Полученные в ходе исследования данные статистически достоверны для наблюдаемого взаимодействия. К потенциальным ограничениям исследования следует отнести возможное влияние неучтенных смешивающих факторов, таких как вариабельность внутри исследуемых групп по возрасту животных, живой массе, номеру лактации и т. д. Подтверждение биологических механизмов требует дополнительных функциональных исследований.

Ключевые слова: коровы, голштинская порода, экстерьерные показатели, высота в крестце, ширина в маклоках, ширина в седалищных буграх, полиморфизмы, генетические ассоциации, селекция

Финансирование. Работа выполнена в рамках Государственного задания Министерства науки и высшего образования Российской Федерации по теме № 0532-2025-0003 «Разработка высокоточных методов идентификации генетических детерминант устойчивости к заболеваниям для использования в селекции крупного рогатого скота».

Для цитирования. Бытов М.В., Зубарева В.Д., Краснощёров А.С., Безбородова Н.А., Печёнкина М.А., Соколова О.В. Поиск ассоциаций однонуклеотидных полиморфизмов с показателями экстерьера (тазовые параметры) коров голштинской породы. *Ветеринарная патология.* 2026;25(1):41–49. <https://doi.org/10.23947/2949-4826-2026-25-1-41-49>

Introduction. In modern animal husbandry, the exterior of cattle is an important production indicator directly affecting health, productivity, and reproductive function [1]. Body constitution indices are taken into account in dairy cow breeding among the primal indicators to assess the non-productive traits [2]. Gibson et al. believe that height of a calf is related to the lactation efficiency of an adult cow: taller calves will produce more milk in the future through several

lactations compared to the shorter calves, live weight considered [3]. The results of the study conducted by Schmidtman et al. show that larger animals with visibly protruding bones and a low BCS (Body Condition Score) are more susceptible to metabolic disorders [4].

Exterior traits can be decisive for the development of pathological conditions in animals. For example, sacrum anatomy features can be related to the risk of dystocia

(pathological or difficult parturition) [5]. Significantly higher incidence of dystocia has been found in cows with the sacrum size both narrower and, on the contrary, wider than optimal for calving [6]. The influence of a breed on the incidence of dystocia is explained by the differences in a relative body weight at birth, pelvis anatomy, and significant variations in dimensions of pelvis in some breeds [5]. Due to modern breeding focusing on selection of the herd specimens with the highest milk yield and long-term economic productivity, dystocia remains a serious problem with incidence rate estimated at 10 to 50% [7].

The aim of the study is to identify associations of single-nucleotide polymorphisms with pelvic exterior parameters in Holstein cows that are important prerequisites for forming susceptibility to easy or difficult calving. The data obtained will make it possible to determine the genetic markers to be included into the herd improvement breeding programs.

Materials and Methods. The study was carried out at the Department of Genomic Research and Animal Breeding of Ural Research Veterinary Institute, structural division of Ural Federal Agrarian Research Center of the Ural Branch of the Russian Academy of Sciences, in the period from 2023 to 2025. PCR tests of DNA samples from Holstein cows ($n=155$) from two cattle breeding agricultural enterprises (AEs) (AE No. 1, $n=70$; AE No. 2, $n=85$) were performed. The research sample included animals with one or more lactations. The research was held in compliance with the ethical standards, the studies (e.g., blood sampling from the caudal veins of animals) were approved by the Bioethics Committee of Ural Federal Agrarian Research Center, Ural Branch of the Russian Academy of Sciences (Protocol No. 136 of October 13, 2025).

Exterior traits of the animals were assessed across three dimensions: sacrum height, hip width, and ischial tuberosity width. Statistical data for a phenotype — mean values and standard deviations — were calculated using STATISTICA 12 software (StatSoft Inc, USA).

13 Single Nucleotide Polymorphisms (SNPs) were genotyped across entire sample of cows. To perform association tests, the following polymorphic markers were studied: rs134055603, rs137396952, rs109452259, rs110347054, rs110352004, rs133674837, rs109529386, rs109279094, rs109611915, rs134668940, rs41567027, rs43038601, rs41255693, which had previously shown significant associations with a number of physiologically valuable parameters in cattle during GWAS studies:

- productive longevity [8];
- easy calving [9, 10];
- body weight [11];
- carcass length after cutting [12];
- and other parameters of productivity [10, 13].

The article presents both authors' own findings based on TaqMan genotyping technology and earlier described test systems (Table 1).

Based on the genetic data obtained, the relationship of each polymorphic locus with a phenotype was assessed in separate. Five patterns of trait inheritance were assessed using the SNPStats web tool (Institut Català d'Oncologia, Spain) [19] and the SNPAssoc package [20] in R programming environment (Autonomous University of Barcelona, Spain): codominant, dominant, recessive, overdominant, and log-additive; the effect size was interpreted as the odds ratio (the differences in the values of the exterior traits) with a 95% confidence interval compared to alternative allele homozygote.

To conduct association studies using the SNPAssoc package in the R programming environment, the WGassociation function was used. To test for the presence of “gene-gene” interactions, the interactionPval (Phen, data=data, model='co') function was used. Association tests were performed across three pelvic dimensions: sacrum height, hip width, and ischial tuberosity width; the presence of “gene-gene” interactions was also assessed for each of the exterior traits. For a more detailed study of allele combinations contributing to the formation of a trait, taking into account “gene-gene” interactions, a linear model was created: $\text{lm}(\text{"Phen ~"}, \text{"SNP1"}, \text{"**"}, \text{"SNP2"}, \text{data=data})$. With regard to epistatic interactions, this model envisaged sorting through each combination of genotypes and determining mean value of each of these combinations for a phenotype. A post-hoc Bonferroni correction was performed for each analysis

Results. The mean values and standard deviations for sacrum height in Holstein cows were determined to be 161.7 ± 5.3 cm; for hip width — 41.1 ± 3.9 cm; and for ischial tuberosity width — 22.4 ± 2.1 cm.

Larger values of pelvic width proved to ensure sufficient space for successful development of a fetus and easy calving, and necessary space between hindlimbs to ensure a more voluminous cup-shaped udder [21]. Thus, higher values of each of the three exterior traits are considered a favourable phenotype.

Significant effects of rs109452259 SNP on hip width in Holstein cows were acknowledged in codominant, dominant, and log-additive inheritance patterns. The lowest AIC value for rs109452259 was found in the dominant inheritance pattern, with the C/A and A/A genotypes having 2.17 cm difference from C/C; $p\text{-value}=0.0006$.

When studying a phenotype inheritance mechanism, an interesting feature was revealed, i.e. the presence of “gene-gene” interactions among polymorphisms. In the present study, the epistatic interactions for the pairs of rs134055603–rs43038601 and rs134055603–rs137396952 polymorphisms were identified according to the codominant inheritance pattern (Fig. 1). The significance level for these pairs was corrected to $\alpha < 0.00032$.

Oligonucleotides used in the present study for genotyping in cattle

SNP, localization and genomic context	Oligonucleotides	Amplicon, bp	Source
rs133674837 6:21766662 <i>BDH2</i>	F, AAAGAAGGTGCCAAAGT	91	This study
	R, TCAAGCTATGGAGGTGCT		
	P1, [R6G]ATCAATGACTCCAAACT[BHQ1]		
	P2, [ROX]ATATCAATGAATCCAAACT[BHQ2]		
rs41567027 6:43657946 <i>PPARGC1A</i>	F, CACTAGAAAGCACACTTCA	197	This study
	R, ATACTTGGCTGTGTGGAA		
	P1, [R6G]AGAAGCCGCAAGGTCA[BHQ1]		
	P2, [ROX]CAGAAGCTGCAAGGTCA[BHQ2]		
rs109279094 6:45175137 <i>PPARGC1A</i>	F, ACTAAACCTCTCTGTCTT	338	This study
	R, GATTTGTGTCAGTCTCT		
	P1, [R6G]TCCCCAGACTCATAA[BHQ1]		
	P2, [ROX]CTCCCCTAGACTCATAAC[BHQ2]		
rs109611915 6:88739941 <i>GC – NPFFR2</i>	F, CCTTGTAATGCAGAATCCAC	132	This study
	R, GAACCAACGTTGACCTGAT		
	P1, [R6G]TCATTTTGAGATAACAGAAC[BHQ1]		
	P2, [ROX]TCATTTTGAAGATAACAGAACTA[BHQ2]		
rs110347054 6:88751491 <i>GC – NPFFR2</i>	F, GGAGCTGGGATTGATGCCTAC	226	[14]
	R, AAGAAAATCA+CA+CTTCAAAAGGATA		
	P1, [ROX]CCTACTCCCTC+C+A+CTGGGTG[BHQ2]		
	P2, [Cy5]CCTACTCCCTCC+G+CTGGGTG[BHQ2]		
rs109452259 6:88800322 <i>GC – NPFFR2</i>	F, GCAAAAACACAATATGCTGGAT	415	[16, 15]
	R, AGGTCAAACAACATAACAGTGG		
	P1, [ROX]CTTGTC+A+A+CTT+C+CA[BHQ2]		
	P2, [FAM]CTTGTC+A+C+CTTCCA[BHQ1]		
rs137396952 6:88817457 <i>GC – NPFFR2</i>	F, ATGCAGCAGAAACAAGGGTAAA	225	[17]
	R, GTACAGCCACTGTGCAACAAC		
	P1, [HEX]GA+TT+CAGCATG+G+T+G+TCAG[BHQ2]		
	P2, [Cy5]GATT+CAGCATG+G+C+G+TCAG[BHQ3]		
rs134055603 6:88832335 <i>GC – NPFFR2</i>	F, GACAAGGCTTTTGATAGGTGAAA	316	[17]
	R, CAAAGCAACCACACAATGTTG		
	P1, [HEX]CAT+TT+TCT+T+A+GA+CT+T+CTG[BHQ1]		
	P2, [Cy5]CATTTTCT+T+G+GA+CT+T+CTG[BHQ3]		
rs134668940 6:88838658 <i>GC – NPFFR2</i>	F, GGCAGAGAACTTGACT	276	This study
	R, AGTATCTTG+GCCTCTT		
	P1, [R6G]AGAATAGCACATGGCACA[BHQ1]		
	P2, [ROX]TAGAATAGCAAATGGCACATA[BHQ2]		
rs110352004 6:88948552 <i>GC – NPFFR2</i>	F, GTAGGGATT+GAT+GC+CCTTGAA	232	[14]
	R, TACAATA+CA+C+CATAT+CTTTTCATCC		
	P1, [HEX]AA+TA+C+GTAC+AA+CACT+CT+T[BHQ1]		
	P2, [ROX]TA+C+GTAC+GA+CACTCTGT[BHQ2]		
rs109529386 25:26982725 <i>LOC100847190 – ZNF688</i>	F, ACTAAAGATCCCACGTGCTA	500	This study
	R, GTCTTACTACTGTCCCCACA		
	P1, [R6G]AAGGTGCCACAGCCAGA[BHQ1]		
	P2, [ROX]AGGTGCCGCAGCCA[BHQ2]		
rs43038601 18:57032285 <i>TRNAG-UCC – TRNAG-UCC</i>	F, TGATAACACGTACA+GAGT	180	This study
	R, CAATAAGGCGATTTCGTGG		
	P1, [R6G]TGGTGTCTCGGTTGC[BHQ1]		
	P2, [ROX]TGTCTAGGTTGCTTTACTG[BHQ2]		
rs41255693 26:21272422 <i>SCD1</i>	F, CCCTTATGACAAGACCATCAACC	90	[18]
	R, GACGTGGTCTTGCTGTGGACT		
	P1, [FAM]CTTACCCACAGCTCCCA[BHQ1]		
	P2, [HEX]TACCCGCAGCTCCC[BHQ1]		

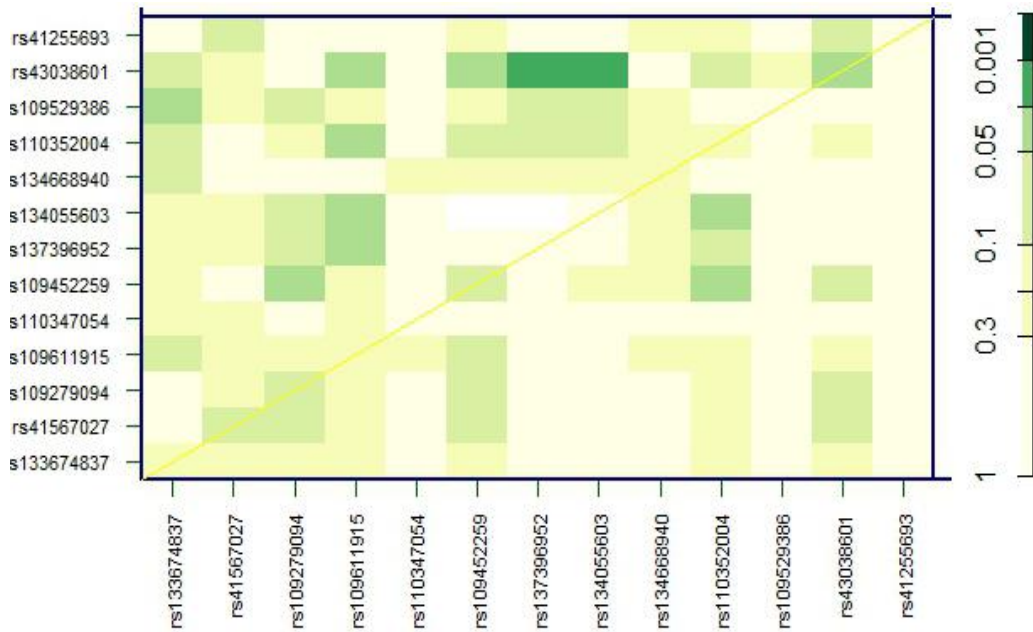

Fig. 1. Screening for the presence of epistatic and additive interactions among polymorphisms in relation to sacrum height parameter inheritance in Holstein cows

A statistically significant epistatic interaction was found for rs134055603 polymorphism. This SNP has a significantly positive contribution to sacrum height only in the presence of A* allele in a genotype identified by rs43038601 polymorphism, while its absence (the combination of G/G and C/C genotypes identified by rs134055603 and rs43038601, respectively) has a negative effect on the phenotype (Fig. 2). It is worth noting that the number of specimens of A/A genotype identified by rs43038601 polymorphism for each of the three combinations was ≤ 3 . Therefore, interpretation of these genotype

combinations is impossible. For each of the other six combinations, the sample size was ≥ 10 .

Epistatic interactions of opposite nature for 134055603 with rs137396952 polymorphism were found. The combination of A* allele in genotype of rs134055603 and the C* allele in genotype of rs137396952 had a positive effect on sacrum height (Fig. 3). It is worth emphasising that the number of specimens with A/A genotype identified by rs43038601 polymorphism for each of the three combinations was ≤ 3 .

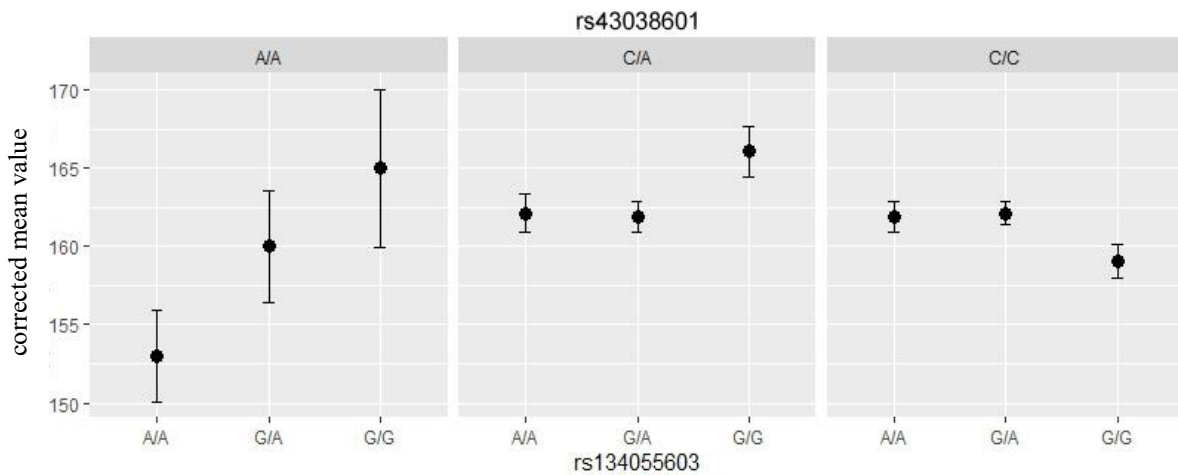

Fig. 2. Facet matrix for the pooled samples of Holstein cows in relation to sacrum height for rs134055603 and rs43038601 epistatic interaction. Corrected $R^2 = 0.0923$. F-test = 2.957. p-value < 0.0043

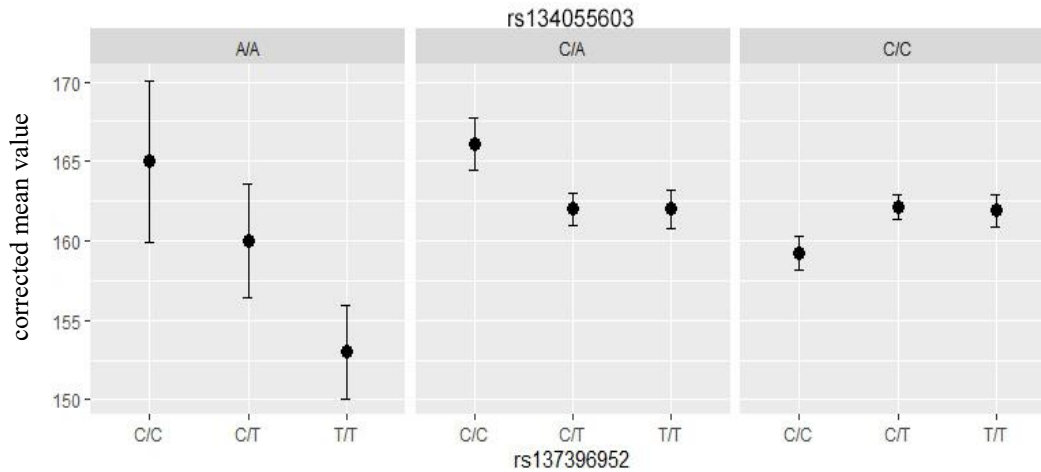

Fig. 3. Facet matrix for the pooled samples of Holstein cows in relation to sacrum height for rs134055603 and rs137396952 epistatic interaction. Adjusted $R^2 = 0.0902$. F-test = 2.909. p-value < 0.0049

Discussion and Conclusion. During the study conducted in 155 Holstein cows, the mean values and standard deviations for sacrum height (161.7 ± 5.3 cm), hip width (41.1 ± 3.9 cm), and ischial tuberosity width (22.4 ± 2.1 cm) were determined. Genotyping of 13 polymorphisms was conducted for each specimen. It was revealed that in Holstein cows, genotyping of rs109452259 requires negative selection by C* allele to increase the hip width. Epistatic interaction of rs134055603 and rs43038601, probably of synergistic nature for G/G and C/A genotypes respectively, was identified. Epistatic interaction of rs134055603 and rs137396952, probably of synergistic nature for the C/A

and C/C genotypes respectively, was identified. The data obtained during the study are significant for the observed-level statistical interaction; for confirmation of the biological mechanisms, further functional studies are required.

The potential limitations of the study include possible influence of the unaccounted confounding factors, such as, variability of the studied groups of animals by age, live body weight, lactation number, and origin (of an agricultural enterprise). The above mentioned limitations could have influenced the results obtained and their subsequent interpretation.

References

- Peng Ch, Cao Sh, Li Sh, Bai T, Zhao Z, Sun W. Automated Measurement of Cattle Dimensions Using Improved Keypoint Detection Combined with Unilateral Depth Imaging. *Animals*. 2024;14(17):2453. <https://doi.org/10.3390/ani14172453>
- Zhang Zh, Yang J, Yao Y, Wang D, Lu X, Yang Zh. Body Conformation Traits in Early-Lactation Associated with Clinical Mastitis and Lameness in Lactating Chinese Holstein Cows. *BMC Veterinary Research*. 2024;20(1):85. <https://doi.org/10.1186/s12917-024-03931-1>
- Gibson MJ, Adams BR, Back PJ, Hickson RE, Dittmer KE, Rogers CW. Live Weight and Bone Growth from Birth to 23 Months of Age in Holstein-Friesian, Jersey and Crossbred Heifers. *Dairy*. 2022;3(2):333–344. <https://doi.org/10.3390/dairy3020026>
- Schmidtman C, Segelke D, Bennewitz J, Tetens J, Thaller G. Genetic Analysis of Production Traits and Body Size Measurements and Their Relationships with Metabolic Diseases in German Holstein Cattle. *Journal of Dairy Science*. 2023;106(1):421–438. <https://doi.org/10.3168/jds.2022-22363>
- Bila L, Tyasi TL, Fourie P, Katikati A. Classification and Regression Tree Analysis to Predict Calving Ease in Sussex Heifers Using Pelvic Area Dimensions and Morphological Traits. *Journal of Advanced Veterinary and Animal Research*. 2021;8(1):164–172. <https://doi.org/10.5455/javar.2021.h499>
- Sawa A, Bogucki M, Krężel-Czopek S, Neja W. Association between Rump Score and Course of Parturition in Cows. *Archiv Tierzucht (Archives Animal Breeding)*. 2013;56(81):816–822. <https://doi.org/10.7482/0003-9438-56-081>
- Crociati M, Sylla L, De Vincenzi A, Stradaoli G, Monaci M. How to Predict Parturition in Cattle? A Literature Review of Automatic Devices and Technologies for Remote Monitoring and Calving Prediction. *Animals*. 2022;12(3):405. <https://doi.org/10.3390/ani12030405>
- Nayeri S, Sargolzaei M, Abo-Ismael MK, Miller S, Schenkel F, Moore SS, Stothard P. Genome-Wide Association Study for Lactation Persistency, Female Fertility, Longevity, and Lifetime Profit Index Traits in Holstein Dairy Cattle. *Journal of Dairy Science*. 2017;100(2):1246–1258. <https://doi.org/10.3168/jds.2016-11770>

9. Abo-Ismael MK, Brito LF, Miller SP, Sargolzaei M, Grossi DA, Moore SS, et al. Genome-Wide Association Studies and Genomic Prediction of Breeding Values for Calving Performance and Body Conformation Traits in Holstein Cattle. *Genetics, Selection, Evolution*. 2017;49:82. <https://doi.org/10.1186/s12711-017-0356-8>
10. Jiang J, Li M, Prakapenka D, VanRaden PM, Cole JB, Da Y. A Large-Scale Genome-Wide Association Study in U.S. Holstein Cattle. *Frontiers in Genetics*. 2019;10:412. <https://doi.org/10.3389/fgene.2019.00412>
11. Snelling WM, Allan MF, Keele JW, Kuehn LA, McDanel T, Smith TP, et al. Genome-Wide Association Study of Growth in Crossbred Beef Cattle. *Journal of Animal Science*. 2010;88(3):837–848. <https://doi.org/10.2527/jas.2009-2257>
12. Liu R, Fang X, Lu X, Liu Y, Li Y, Bai X, et al. Polymorphisms of the SCD1 Gene and Its Association Analysis with Carcass, Meat Quality, Adipogenic Traits, Fatty Acid Composition, and Milk Production Traits in Cattle. *Animals*. 2024;14(12):1759. <https://doi.org/10.3390/ani14121759>
13. Pozovnikova MV, Serdyuk GN, Tulinova OV, Terletskiy VP, Dementeva NV, Mitrofanova OV. Association of Polymorphic Types of Stearoyl-Coa Desaturase Gene (*SCD1*) with Economically Valuable Traits in Russian Population of Ayrshire Cows. *Agricultural Biology*. 2017;52(6):1139–1147. (In Russ.) <https://doi.org/10.15389/agrobiol-ogy.2017.6.1139eng>
14. Bytov MV, Nokhrin DYu, Zubareva VD, Isaeva AG, Sokolova OV. Post-GWAS Study of the Predisposition of Cows of Different Breeds to Mastitis. *Agrarian Bulletin of the Urals*. 2024;24(12):1648–1672. (In Russ.) <https://doi.org/10.32417/1997-4868-2024-24-12-1648-1672>
15. Bytov MV, Zubareva VD, Volskaya SV, Isaeva AG, Nokhrin DY, Osipova YA, et al. Assessing the Genetic Diversity of Five Cattle Breeds Using SNP Markers Associated with Health. *Russian Journal of Genetics*. 2024;60(6):55–61. (In Russ.) <https://doi.org/10.31857/S0016675824060056>
16. Bytov MV, Zubareva VD, Volskaya SV, Isaeva AG, Nokhrin DY, Osipova YA, et al. Assessing the Genetic Diversity of Five Cattle Breeds Using SNP Markers Associated with Health. *Russian Journal of Genetics*. 2024;60:747–753. <https://doi.org/10.1134/S1022795424700182>
17. Bytov MV, Sokolova OV, Bezborodova NA, Krasnoperov AS, Isaeva AG. Cattle Genotyping Methods for Post-GWAS Annotation of SNPs. *Agrarian Bulletin of the Urals*. 2023;235(6):67–75. (In Russ.) <https://doi.org/10.32417/1997-4868-2023-235-06-67-75>
18. Kovalchuk SN, Arkhipova AL, Klimov EA, Skachkova OA. *Method for Cattle Genotyping by Alleles 878 of scd1 (rs41255693) Gene by PCR in Real Time*. Patent of the Russian Federation No 2744174. 2021. (In Russ.)
19. Solé X, Guinó E, Valls J, Iniesta R, Moreno V. SNPStats: A Web Tool for the Analysis of Association Studies. *Bioinformatics*. 2006;22(15):1928–1929. <https://doi.org/10.1093/bioinformatics/btl268>
20. González JR, Armengol L, Solé X, Guinó E, Mercader JM, Estivill X, et al. SNPAssoc: an R Package to Perform Whole Genome Association Studies. *Bioinformatics*. 2007;23(5):644–645. <https://doi.org/10.1093/bioinformatics/btm025>
21. Boyarina OA. Linear Assessment of the Exterior of Holstein Cows According To The Canadian System. *Bulletin of KSAU*. 2025;(221):156–165. (In Russ.) <https://doi.org/10.36718/1819-4036-2025-8-156-165>

About the Authors:

Maksim V. Bytov, Postgraduate Student, Junior Research Associate of the Genomic Research and Animal Breeding Department, Ural Federal Agrarian Research Center of the Ural Branch of the Russian Academy of Sciences (112a, Belinsky Str, P.O. Box 269, Ekaterinburg, 620142, Russian Federation), [SPIN-код](#), [ORCID](#), [Researcher ID](#), [Scopus ID](#), bytovmaks@mail.ru

Vladlena D. Zubareva, Junior Research Associate of the Genomic Research and Animal Breeding Department, Ural Federal Agrarian Research Center of the Ural Branch of the Russian Academy of Sciences (112a, Belinsky Str., P.O. Box 269, Ekaterinburg, 620142, Russian Federation), [SPIN-код](#), [ORCID](#), [Researcher ID](#), [Scopus ID](#), zzub97@mail.ru

Alexander S. Krasnoperov, Cand.Sci. (Veterinary), Head of the Laboratory of Immunology and Pathobiochemistry, Ural Research Veterinary Institute, Ural Federal Agrarian Research Center of the Ural Branch of the Russian Academy of Sciences (112a, Belinsky Str., P.O. Box 269, Ekaterinburg, 620142, Russian Federation), [SPIN-код](#), [ORCID](#), [Researcher ID](#), [Scopus ID](#), marafon.86@list.ru

Natalia A. Bezborodova, Cand.Sci. (Veterinary), Head of the Genomic Research and Animal Breeding Department, Ural Research Veterinary Institute, Ural Federal Agrarian Research Center of the Ural Branch of the Russian Academy of Sciences (112a, Belinsky Str., P.O. Box 269, Ekaterinburg, 620142, Russian Federation), [SPIN-код](#), [ORCID](#), [Scopus ID](#), n-bezborodova@mail.ru

Marina A. Pechenkina, Laboratory Assistant of the Genomic Research and Animal Breeding Department, Ural Federal Agrarian Research Center of the Ural Branch of the Russian Academy of Sciences (112a, Belinsky Str., P.O. Box 269, Ekaterinburg, 620142, Russian Federation), [SPIN-код](#), [ORCID](#), [Researcher ID](#), [Scopus ID](#), pn190503@mail.ru

Olga V. Sokolova, Dr.Sci. (Veterinary), Director of the Ural Research Veterinary Institute, Ural Federal Agrarian Research Center of the Ural Branch of the Russian Academy of Sciences (112a, Belinsky Str., P.O. Box 269, Ekaterinburg, 620142, Russian Federation), [SPIN-код](#), [Researcher ID](#), [Scopus ID](#), nauka_sokolova@mail.ru

Claimed Contributorship:

MV Bytov: development of methodology, formal analysis, preparing the draft of the manuscript.

VD Zubareva: conducting experiments and data collection, preparing the draft of the manuscript.

AS Krasnoperov: conducting experiments and data collection.

NA Bezborodova: conducting experiments and data collection.

MA Pechenkina: manuscript editing and refining.

Sokolova OV: manuscript editing and refining.

Conflict of Interest Statement: the authors declare no conflict of interest.

All authors have read and approved the final manuscript.

Об авторах:

Максим Владимирович Бытов, аспирант, младший научный сотрудник отдела геномных исследований и селекции животных Уральского научно-исследовательского ветеринарного института, Уральский федеральный аграрный научно-исследовательский центр Уральского отделения Российской академии наук (620142, Российская Федерация, г. Екатеринбург, а/я 269, ул. Белинского, 112а), [SPIN-код](#), [ORCID](#), [Researcher ID](#), [Scopus ID](#), bytovmaks@mail.ru

Владлена Дмитриевна Зубарева, младший научный сотрудник отдела геномных исследований и селекции животных Уральского научно-исследовательского ветеринарного института, Уральский федеральный аграрный научно-исследовательский центр Уральского отделения Российской академии наук (620142, Российская Федерация, г. Екатеринбург, а/я 269, ул. Белинского, 112а), [SPIN-код](#), [ORCID](#), [Researcher ID](#), [Scopus ID](#), zzub97@mail.ru

Александр Сергеевич Красноперов, кандидат ветеринарных наук, заведующий лабораторией иммунологии и патобиохимии Уральского научно-исследовательского ветеринарного института, Уральский федеральный аграрный научно-исследовательский центр Уральского отделения Российской академии наук (620142, Российская Федерация, г. Екатеринбург, а/я 269, ул. Белинского, 112а), [SPIN-код](#), [ORCID](#), [Researcher ID](#), [Scopus ID](#), marafon.86@list.ru

Наталья Александровна Безбородова, кандидат ветеринарных наук, заведующий отделом геномных исследований и селекции животных Уральского научно-исследовательского ветеринарного института, Уральский федеральный аграрный научно-исследовательский центр Уральского отделения Российской академии наук (620142, Российская Федерация, г. Екатеринбург, а/я 269, ул. Белинского, 112а), [SPIN-код](#), [ORCID](#), [Scopus ID](#), n-bezborodova@mail.ru

Марина Андреевна Печёнкина, лаборант отдела геномных исследований и селекции животных Уральского научно-исследовательского ветеринарного института, Уральский федеральный аграрный научно-исследовательский центр Уральского отделения Российской академии наук (620142, Российская Федерация, г. Екатеринбург, а/я 269, ул. Белинского, 112а),

Ольга Васильевна Соколова, доктор ветеринарных наук, руководитель Уральского научно-исследовательского ветеринарного института, Уральский федеральный аграрный научно-исследовательский центр Уральского отделения Российской академии наук (620142, Российская Федерация, г. Екатеринбург, а/я 269, ул. Белинского, 112а), nauka_sokolova@mail.ru

Заявленный вклад авторов:

М.В. Бытов: разработка методологии, формальный анализ; подготовка первоначального варианта рукописи.

В.Д. Зубарева: проведение экспериментов и сбор данных; подготовка первоначального варианта рукописи.

А.С. Красноперов: проведение экспериментов и сбор данных.

Н.А. Безбородова: проведение экспериментов и сбор данных.

М.А. Печёнкина: редактирование и доработка рукописи.

О.В. Соколова: редактирование и доработка рукописи.

Конфликт интересов: авторы заявляют об отсутствии конфликта интересов.

Все авторы прочитали и одобрили окончательный вариант рукописи.

Received / Поступила в редакцию 12.01.2026

Reviewed / Поступила после рецензирования 06.02.2026

Accepted / Принята к публикации 09.02.2026

SANITARY, HYGIENIC, ECOLOGICAL, VETERINARY-SANITARY EXAMINATION AND BIOLOGICAL SAFETY

САНИТАРИЯ, ГИГИЕНА, ЭКОЛОГИЯ, ВЕТЕРИНАРНО-САНИТАРНАЯ ЭКСПЕРТИЗА И БИОБЕЗОПАСНОСТЬ



UDC: 636.09

Original Empirical Research

<https://doi.org/10.23947/2949-4826-2026-25-1-50-62>

Uncontrollable Mortality in Agricultural Animals in the Russian Federation: A State-Level Problem in the Context of Sanction Restrictions

Elena O. Mirgorodskaya  ✉, Yulia L. Stepanova , Igor O. Potapenko , Alexey M. Ermakov 

Don State Technical University, Rostov-on-Don, Russian Federation

✉ emirgorod@mail.ru



EDN: VORTNY

Abstract

Introduction. Uncontrollable mortality in agricultural animals causes significant economic damage to the producers, and threatens the national food security. In the context of sanction restrictions, and the need to ensure the independence from import supplies, the problem of livestock mortality control has become particularly acute in the Russian Federation. Although the statistical data are available, the comprehensive analysis of the correlation of livestock mortality and population dynamics, as well as analysis of the factors inducing the growth of mortality are insufficiently presented in the scientific literature. This determines the relevance and purpose of the present study.

Materials and Methods. The study was conducted based on the data of the Federal State Statistics Service of the Russian Federation (Rosstat) for the period of 2019–2023. The methods of economic and statistical analysis were used, including the analysis of time series, calculation of livestock population growth rate, structural analysis of the share of mortality in the total figure of livestock population, and comparative analysis of the mortality and population rate changes in the main groups of agricultural animals.

Results. The situation has been identified as critical in pig farming, where the livestock mortality-to-population ratio has increased from 32.2% in 2019 to 43.1% in 2023, and in reindeer herding, where this indicator has reached from 14.9 to 19.0%. In most of the animal groups (cattle, pigs, sheep, goats, and horses), the mortality growth rate was found to significantly exceed the population growth rate, and the amplitude of mortality fluctuations was higher, indicating the insufficient level of process control. The key groups of factors influencing mortality have been identified: natural and climatic factors (natural disasters, dangerous diseases), technical and organisational factors (feed shortage, unsatisfactory condition of the premises), and organisational and human (low qualified staff, belated veterinary care).

Discussion and Conclusion. The obtained results confirm the existence of a systemic problem of uncontrollable mortality in agricultural animals in the Russian Federation, which requires a transition from the local measures to the State regulation. A set of measures has been proposed, including planning the actions of agricultural enterprises that face the livestock mortality threat, developing an insurance system, strengthening the state support, upgrading employee qualifications, and expanding statistical recording. Implementation of these measures will improve the predictability of livestock population dynamics, reduce the socioeconomic damage caused by the livestock mortality, and strengthen the food security of the country.

Keywords: livestock mortality, Russian Federation, agricultural animals, uncontrollable mortality, pig farming, reindeer, cattle, food security, state regulation, veterinary control, mortality statistics, veterinary internship

For Citation: Mirgorodskaya EO, Stepanova YuL, Potapenko IO, Ermakov AM. Uncontrollable Mortality in Agricultural Animals in the Russian Federation: A State-Level Problem in the Context of Sanction Restrictions. *Russian Journal of Veterinary Pathology*. 2026;25(1):50–62 <https://doi.org/10.23947/2949-4826-2026-25-1-50-62>

Неконтролируемый падеж сельскохозяйственных животных в Российской Федерации: государственная проблематика в условиях санкционных ограничений

Е.О. Миргородская  ✉, Ю.Л. Степанова , И.О. Потапенко , А.М. Ермаков 

Донской государственный технический университет, г. Ростов-на-Дону, Российская Федерация

✉ emirgorod@mail.ru

Аннотация

Введение. Неконтролируемая гибель сельскохозяйственных животных наносит значительный экономический ущерб производителям и создает угрозу продовольственной безопасности государства. В условиях санкционных ограничений и необходимости обеспечения импортонезависимости проблема управления падежом скота в Российской Федерации приобретает особую остроту. Несмотря на наличие статистических данных, в научной литературе недостаточно внимания уделяется комплексному анализу соотношения динамики падежа и поголовья, а также выявлению факторов, приводящих к росту смертности, что определяет актуальность и цель данного исследования.

Материалы и методы. Исследование выполнено на основе данных Федеральной службы государственной статистики РФ (Росстат) за 2019–2023 гг. Используются методы экономико-статистического анализа, включая анализ динамических рядов, расчет темпов прироста, структурный анализ доли падежа в общем поголовье, а также сравнительный анализ темпов изменения падежа и поголовья по основным видам сельскохозяйственных животных.

Результаты исследования. Выявлено, что критическая ситуация наблюдается в свиноводстве, где доля падежа к поголовью выросла с 32,2 % в 2019 г. до 43,1 % в 2023 г., а также в оленеводстве, где этот показатель достигает 14,9–19,0 %. Установлено, что по большинству групп животных (крупный рогатый скот, свиньи, овцы и козы, лошади) темпы роста падежа значительно превышают темпы роста поголовья, а амплитуда колебаний падежа выше, что свидетельствует о недостаточном уровне управления процессом. Определены ключевые группы факторов, влияющих на падеж: природно-климатические (стихийные бедствия, опасные болезни), технико-организационные (недостаток кормов, неудовлетворительное состояние помещений) и организационно-человеческие (низкая квалификация персонала, несвоевременная ветеринарная помощь).

Обсуждение и заключение. Полученные результаты подтверждают наличие системной проблемы неконтролируемого падежа скота в РФ, требующей перехода от локальных мер к государственному регулированию. Предложен комплекс мероприятий, включающий планирование действий сельскохозяйственной организации при угрозе падежа, развитие системы страхования, усиление государственной поддержки, повышение квалификации работников и расширение статистического учета. Реализация данных мер позволит повысить прогнозируемость динамики поголовья, снизить социально-экономический ущерб от падежа и укрепить продовольственную безопасность страны.

Ключевые слова: падеж скота, Российская Федерация, сельскохозяйственные животные, неконтролируемая смертность, свиноводство, северные олени, крупный рогатый скот, продовольственная безопасность, государственное регулирование, ветеринарный контроль, статистика падежа, ветеринарная интернатура

Для цитирования. Миргородская Е.О., Степанова Ю.Л., Потапенко И.О., Ермаков А.М. Неконтролируемый падеж сельскохозяйственных животных в Российской Федерации: государственная проблематика в условиях санкционных ограничений. *Ветеринарная патология*. 2026;25(1):50–62. <https://doi.org/10.23947/2949-4826-2026-25-1-50-62>

Introduction. Livestock mortality is a significant socio-economic problem not only for agricultural enterprises engaged in livestock farming but for the country as a whole. Excessive livestock mortality leads to losses of livestock products, valuable animal genetic resources, labour and financial investments, and expected profit due to the inability of the agricultural enterprises to fully complete the production cycle. At the state level, livestock mortality can entail a chain of inflationary processes, starting with the rise of livestock product prices and leading to the rise of prices in the related sectors. Such processes are highly probable, as the demand for the livestock products won't decline, but rather increase with population growth due to

essential role of livestock products in a human diet. Uncontrollable livestock mortality can cause social problems such as unemployment in livestock farming and related sectors, and serious environmental problems due to the need to dispose a large number of cadavers of dead animals. All this poses a real threat to the food security of the country.

The problem is highly relevant for the Russian Federation: reduction of beef production leads to the growth of prices for this type of meat and fall of its affordability for people, which automatically results in increased share of pork and poultry in their diet, and can cause problems in these sectors in the event of crises similar to the one in

poultry farming in 2025. On the other hand, this may require enlargement of meat and meat products' export, which creates risks for the domestic market of the Russian Federation in case of changes in political and economic situation. Therefore, livestock mortality control is crucial for the development of agricultural enterprises and improvement of their cost-efficiency, as well as for ensuring the economic, food, and environmental security of the country in the context of sanction restrictions⁶ [1]. However, despite the availability of statistical data, little attention has been paid in the scientific literature to a comprehensive analysis of the correlation between the dynamics of livestock mortality and livestock population, as well as to identifying the factors influencing excessive mortality.

The aim of the study is to evaluate the state of livestock mortality in the agricultural enterprises of the Russian Federation, identify factors leading to excessive livestock mortality, and propose measures to improve livestock mortality control and reduce socio-economic damage.

Materials and Methods. The empirical study was based on the official data of the Federal State Statistics Service of the Russian Federation (Rosstat) for the period of 2019–2023. Monthly and annual bulletin “Livestock Population in the Farms of All Categories” served the source of information on the numbers of agricultural animals by species; the bulletin “State of Livestock Farming” served the source of information on animal mortality in the agricultural enterprises (small business entities excluded). In this study, livestock mortality is understood as the death of an animal due to the direct impact of certain factors

(dangerous diseases, natural disasters, etc.) or due to euthanasia reasoned by the inability to help an animal suffering from these factors.

The research was carried out using the following economic and statistical methods: the analysis of time series of livestock population and mortality per each year in absolute values; calculation of the rates of changing (increase/decrease) of both livestock population and mortality for each animal species separately; the structural analysis to determine the mortality-to-population ratio (as a percentage), which made it possible to evaluate severity of the situation. For each animal species, the direction and fluctuation amplitude of livestock population and mortality growth rate were compared. Mortality rates exceedance over livestock population rates, divergency of trends, and increased volatility of mortality were interpreted as signs of insufficient process control.

Research Results

Dynamics of livestock population and mortality in the Russian Federation. To objectively assess the impact of livestock mortality on the state of livestock farming, it is necessary to understand the volumes of livestock farming production in the country. According to the Rosstat data for 2019–2023, there was a positive growth dynamics in the amount of produced and raised livestock and poultry, by volume (thousand tons): the largest upsurge of this indicator equal to 6.28% was observed in 2022 compared to 2021; in 2023, the increase was 2.18% compared to 2022 (Fig. 1).⁷

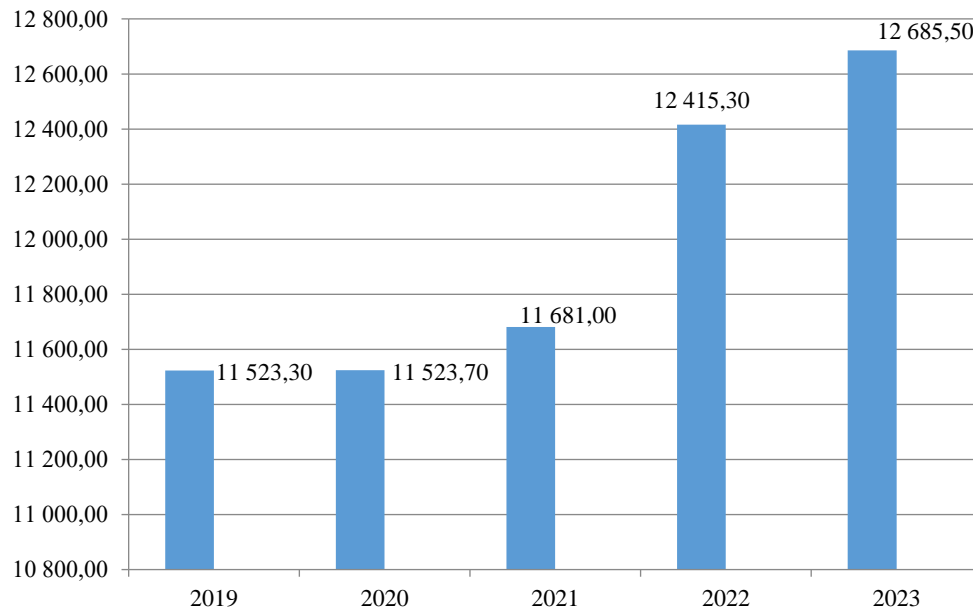

Fig. 1. The amount of produced and raised livestock and poultry in the Russian Federation in 2019–2023, thousand tons

⁶ On Approval of the Doctrine of Food Security of the Russian Federation. Executive Order of the President of the Russian Federation No. 20 of January 21, 2020. URL: <https://www.garant.ru/products/ipo/prime/doc/73338425/> (accessed: 09.09.2025)

⁷ State of Livestock Farming. Bulletin for 2019–2023. Federal State Statistics Service. URL: <https://rosstat.gov.ru/compendium/document/13277> (accessed: 12.02.2024)

The analysis of Table 1 shows that in 2023, compared to 2022, cattle population decreased by 1.98%; cow population decrease dynamics in 2023 compared to 2022 was 2.48%; during the studied years, negative population dynamics was observed in horses, sheep and goats, and reindeer. Positive population dynamics was observed in pigs (by 6.85% in 2022 compared to 2021 and by 3.13% in 2023 compared to 2022). In 2023, there was an increase in the population of camels by 1.88%, donkeys — by 20.83%, mules and hinnies — by 75% compared to 2022.⁸

The analysis of Table 2 shows an increase in livestock mortality in the agricultural enterprises in 2023 compared to 2022, which was observed for all groups of agricultural animals except for cattle (the mortality in this group decreased in 2023 compared to 2022 by 4.917%). In 2023,

the greatest increase of mortality was observed in the following groups of animals: camels by 73.3%; sheep and goats by 22.35%; pigs by 12.95%; poultry by 12.32%. Also, an increase of young cattle mortality should be noted in 2023 compared to 2022, especially that of reindeer calves (by 20.15%), although in previous years there was a constant decrease in mortality. The mortality in lambs and goatlings also increased significantly in 2023 — by 13.18%. A positive trend for steady decline of mortality was observed in foals from 2019 to 2023, although, in adult horses, the mortality was observed to increase in 2023 by 2.6%. It should be noted that in 2022, the mortality had decreased in most animal groups, whereas in 2023, on the contrary, it increased significantly.⁹

Table 1

Livestock population dynamics in the agricultural enterprises of the Russian Federation in 2019–2023

Livestock population, thousand heads	2019	2020	2021	2022	2023	Rate of changing			
						2020/2019	2021/2020	2022/2021	2023/2022
Cattle	8107.5	8123.8	7978.6	7 959.7	7 801.9	0.20	-1.79	-0.24	-1.98
including Cows	3274.1	3270.8	3227.5	3 227.4	3 147.4	-0.10	-1.33	-0.003	-2.48
Pigs	22418.5	23311.3	24005.2	25 650.2	26 453.7	3.98	2.98	6.85	3.13
Sheep and Goats	3552.2	3237.7	3115.7	3 170.4	3 098.9	-8.85	-3.77	1.76	-2.25
Horses	262.4	251.4	238.5	229.7	219.4	-4.18	-5.12	-3.72	-4.46
Reindeer	904.1	881.7	869.2	920.6	890.6	-2.47	-1.42	5.91	-3.25
Camels	4547	4585	4319	3889	3962	0.84	-5.80	-9.96	1.88
Donkeys	37	23	102	96	116	-37,84	343,4	-5,88	20,83
Mules and hinnies	10	5	2	4	7	-50.00	-60.00	100.0	75.00

We will analyse the ratio of the livestock mortality to population for the period of 2019–2023 (Figures 2–9).

Figure 2 shows the proportion of mortality to the total number of livestock population in various animal groups during 2019–2023. The analysis shows that for such groups of agricultural animals as “camels”, “horses”, and “cows”, the proportion of mortality didn’t not exceed 2%, which means the damage from mortality was not critical. A positive trend for the decrease in the values of this indicator in the “cows” and “horses” groups in 2023 compared to previous years is observed.

The proportion of mortality to the total number of livestock population in the “cattle” and “sheep and goats” groups ranged from 2–4% in the studied period.

The agricultural enterprises may suffer significant damage in relation with the “reindeer” group, due to fluctuation of the mortality proportion in this group during the studied period in the range from 13.24% in 2022 to 19.03% in 2019. A positive trend to note is the decrease of the mortality proportion to the total population in 2022–2023 compared to 2019–2021.

⁸ Livestock Population in the Farms of All Categories. Bulletin for 2019–2023. Federal State Statistics Service. URL: <https://rosstat.gov.ru/compendium/document/13277> (accessed: 12.02.2024)

⁹ State of Livestock Farming. Bulletin for 2019–2023. Federal State Statistics Service. URL: <https://rosstat.gov.ru/compendium/document/13277> (accessed: 12.02.2024)

The most critical situation is observed in the “pigs” group: proportion of pig mortality to their total population ranged within very high values, moreover, there was a negative trend for mortality increase from 32.17% in 2019 to 43.07% in 2023. Bearing in mind that pigs are the most

numerous group in the total population of agricultural animals, and due to pork being a highly demanded product on the food market, such high mortality numbers indicate significant damage to both the agricultural enterprises and the state as a whole.^{10,11}

Table 2

Livestock mortality dynamics in the agricultural enterprises of the Russian Federation in 2019–2023

Mortality, thousand heads	2019	2020	2021	2022	2023	Rate of changing			
						2020/2019	2021/2020	2022/2021	2023/2022
Cattle	166.9	167	197.6	211.5	201.1	0.060	18.323	7.034	-4.917
Cows	10.6	11	19.1	5.5	6	3.774	73.636	-71.204	9.091
Pigs	7 211.1	8 450.5	9 598.80	10087.0	11393.3	17.187	13.589	5.086	12.950
Sheep and Goats	101.9	103.5	113.9	92.6	113.3	1.570	10.048	-18.701	22.354
Horses	3119	2460	2681	1917	1967	-21.129	8.984	-28.497	2.608
Reindeer	172	150.3	141.9	121.9	133	-12.616	-5.589	-14.094	9.106
Camels	56	50	63	45	78	-10.714	26.000	-28.571	73.333
Poultry	192 160.00	222 656.00	229 525.30	224 702.30	252 387.30	15.870	3.085	-2.101	12.321
Young cattle mortality, thousand heads									
Calves	108.1	105.2	104.2	98.8	108.5	-2.683	-0.951	-5.182	9.818
Piglets	5 449.7	6 194.7	6 805.4	7 464.0	8 241.7	13.670	9.858	9.678	10.419
Lambs and Goatlings	48.6	45.6	45.9	47.8	54.1	-6.173	0.658	4.139	13.180
Foals	1295	799	799	604	532	-38.301	0.000	-24.406	-11.92
Reindeer Calves	64.2	54.8	51.8	40.2	48.3	-14.642	-5.474	-22.394	20.149

Another negative trend in livestock farming is the exceedance of livestock mortality increase rate over the population growth rate. This situation makes us to forecast further increase in mortality numbers, and decline in livestock population numbers as well as in the potential for herd reproduction. Figures 3–9 illustrate the correlation between the rates of changing the mortality and population numbers in each group of agricultural animals under study.

According to Fig. 3, the rate of changing cattle population is insignificant, ranging from 0.2% in 2019 to -1.98% in 2023. There is a large gap between the rate of changing

cattle population and the rate of changing its mortality, which may indicate the uncontrollability of cattle mortality process^{12,13}. The situation is aggravated by the fact that, with the exception of 2023, the increase of cattle mortality is taking place against the background of the decrease of its population. This could lead to serious problems in this group of animals and contribute to a sharp decline in the amount of beef and veal produced as well as milk and dairy products, which are included in the consumer basket and have a significant share in the structure of food products.

¹⁰ *Livestock Population in the Farms of All Categories*. Bulletin for 2019–2023. Federal State Statistics Service. URL: <https://rosstat.gov.ru/compendium/document/13277> (accessed: 12.02.2024)

¹¹ *State of Livestock Farming*. Bulletin for 2019–2023. Federal State Statistics Service. URL: <https://rosstat.gov.ru/compendium/document/13277> (accessed: 12.02.2024)

¹² *State of Livestock Farming*. Bulletin for 2019–2023. Federal State Statistics Service. URL: <https://rosstat.gov.ru/compendium/document/13277> (accessed: 12.02.2024)

¹³ *Livestock Population in the Farms of All Categories*. Bulletin for 2019–2023. Federal State Statistics Service. URL: <https://rosstat.gov.ru/compendium/document/13277> (accessed: 12.02.2024)

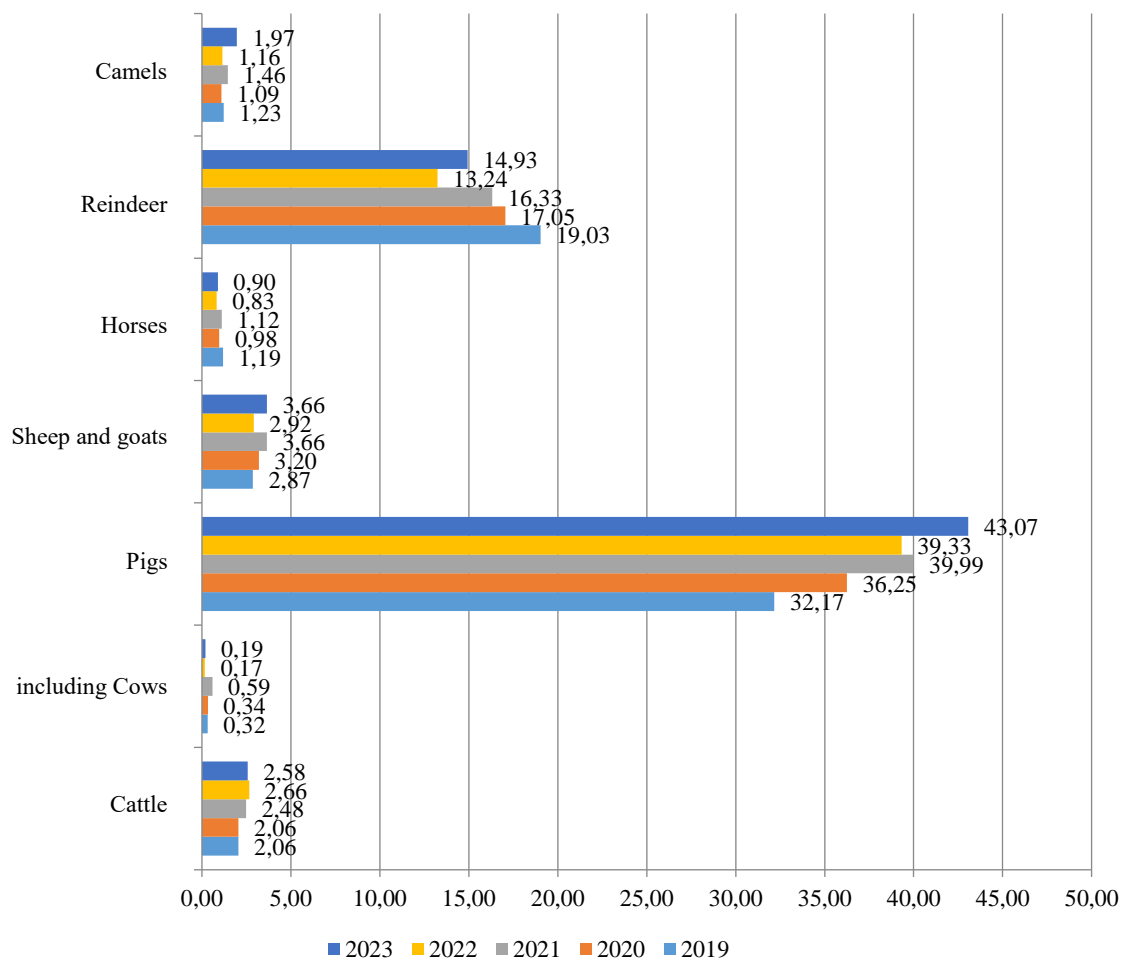

Fig. 2. The proportion of mortality to the total number of livestock population in various groups of agricultural animals in the Russian Federation in 2019–2023

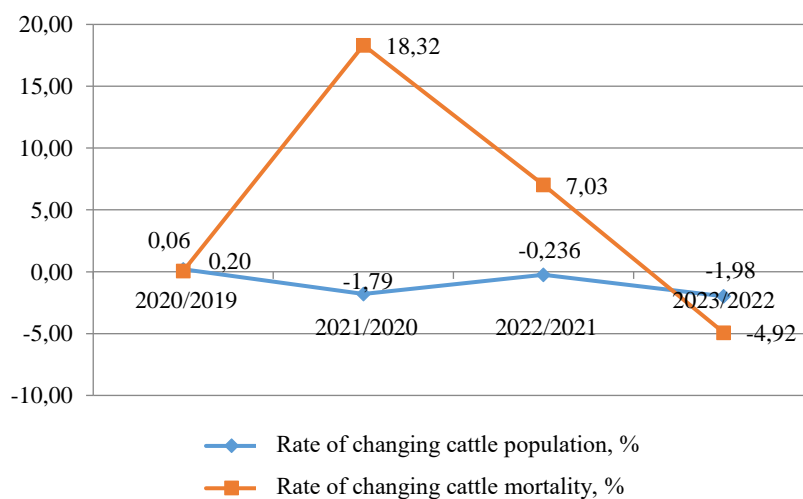

Fig. 3. Rates of changing the cattle population and mortality in the agricultural enterprises of the Russian Federation in 2019–2023

Figure 4 clearly confirms the fact that in cows the fluctuation amplitudes in the rate of changing the mortality are much wider than that in the rate of changing the population. Moreover, according to Rosstat data, the cattle and small ruminant population continues to decline: in the first half of 2025, cattle population decreased by 4.1% compared to the same period of 2024, and cow population decreased by 3.7%^{14,15,16}

According to Fig. 5, throughout the entire period, except for 2022, the rate of mortality growth in pigs exceeded significantly the rate of their population growth. It is also worth noting that the sharper amplitude in the rate of changing pig mortality compared to the rate of changing pig population. This is especially dangerous due to pig mortality proportion reaching more than 40% in 2023 relative to pig population, and pigs are the most numerous group of agricultural animals.^{17,18}

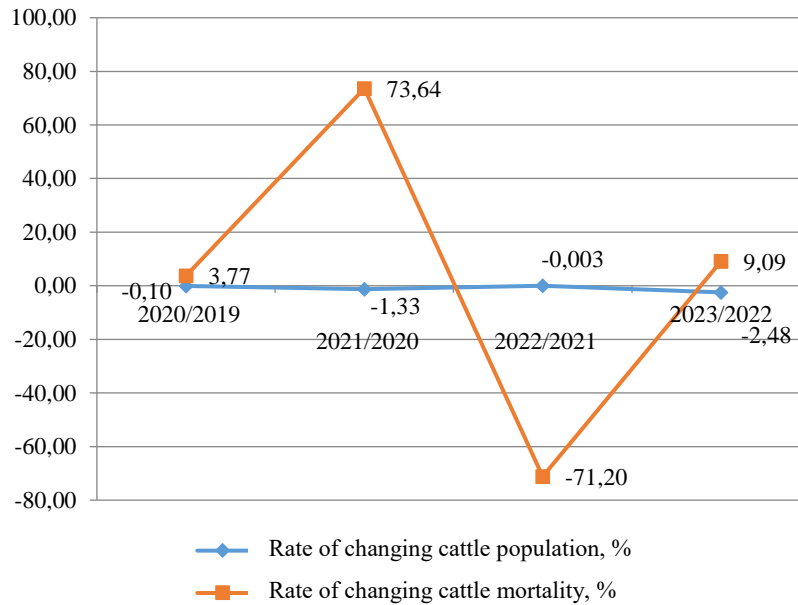

Fig. 4. Rates of changing the cow population and mortality in the agricultural enterprises of the Russian Federation in 2019–2023

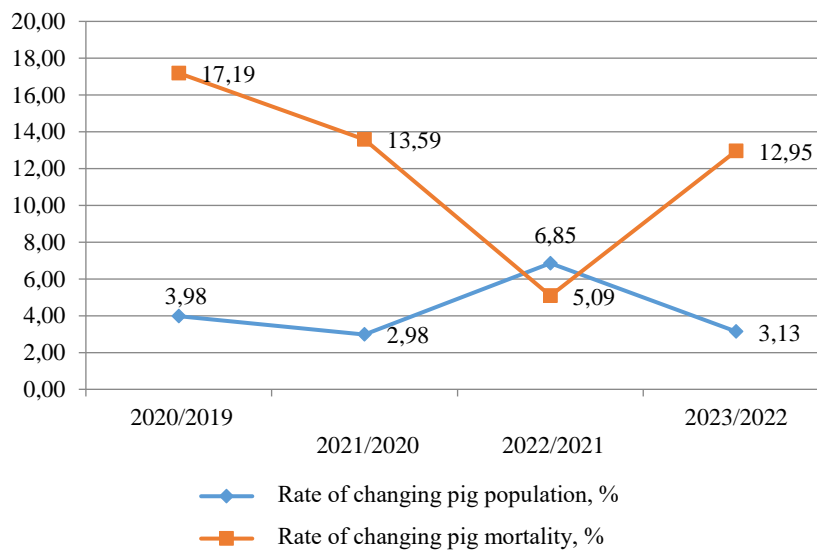

Fig. 5. Rates of changing the pig population and mortality in the agricultural enterprises of the Russian Federation in 2019–2023

¹⁴ Livestock Farming: Results of the First Half of 2025. Agrotrend. URL:

<https://agrotrend.ru/news/52775-zhivotnovodstvo-itogi-i-polugodiya-2025-g> (accessed: 14.02.2026).

¹⁵ State of Livestock Farming. Bulletin for 2019–2023. Federal State Statistics Service. URL: <https://rosstat.gov.ru/compendium/document/13277> (accessed: 12.02.2024)

¹⁶ Ibid.

¹⁷ Livestock Population in the Farms of All Categories. Bulletin for 2019–2023. Federal State Statistics Service. URL: <https://rosstat.gov.ru/compendium/document/13277> (accessed: 12.02.2024)

¹⁸ State of Livestock Farming. Bulletin for 2019–2023. Federal State Statistics Service. URL: <https://rosstat.gov.ru/compendium/document/13277> (accessed: 12.02.2024)

The analysis of Fig. 6 shows the increase in the mortality of sheep and goats against the background of their livestock population decrease registered in 2020, 2021, and 2023. Moreover, the rate of changing the mortality in sheep and goats had a greater amplitude than the rate of changing the livestock population.^{19,20}

The analysis of Fig. 7 also shows a significant amplitude in the rate of changing mortality in horses compared

to the rate of changing their population^{21,22}. However, it is necessary to take into account that in this group of animals the population numbers are significantly greater than the mortality, therefore, the changes in mortality will be more noticeable and will have greater amplitude compared to the population numbers.

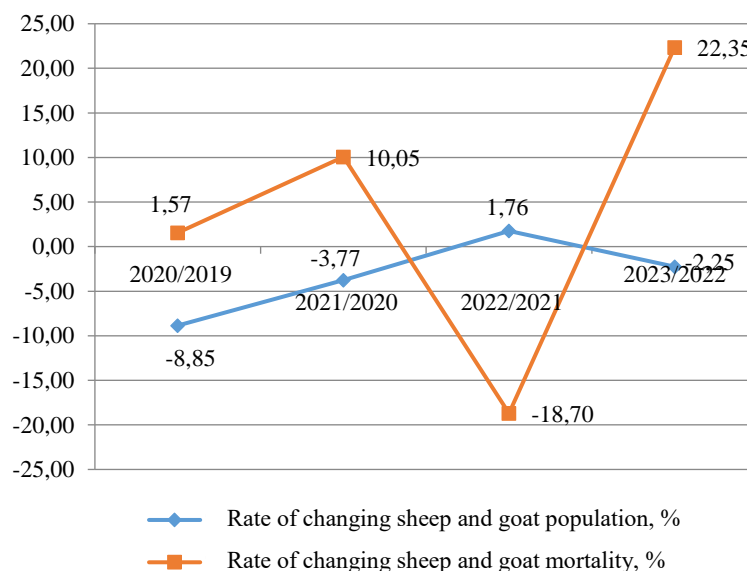

Fig. 6. Rates of changing the population and mortality in sheep and goats in the agricultural enterprises of the Russian Federation in 2019–2023

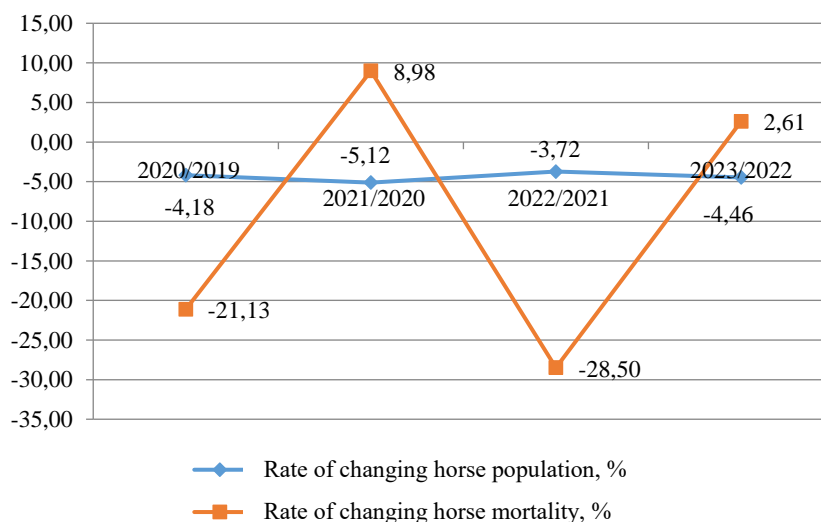

Fig. 7. Rates of changing the horse population and mortality in the agricultural enterprises of the Russian Federation in 2019–2023

¹⁹ *Livestock Population in the Farms of All Categories*. Bulletin for 2019–2023. Federal State Statistics Service. URL: <https://rosstat.gov.ru/compendium/document/13277> (accessed: 12.02.2024)

²⁰ *State of Livestock Farming*. Bulletin for 2019–2023. Federal State Statistics Service. URL: <https://rosstat.gov.ru/compendium/document/13277> (accessed: 12.02.2024)

²¹ *Ibid.*

²² *Livestock Population in the Farms of All Categories*. Bulletin for 2019–2023. Federal State Statistics Service. URL: <https://rosstat.gov.ru/compendium/document/13277> (accessed: 12.02.2024)

The dynamics in the rate of changing mortality in reindeer in the agricultural enterprises of the Russian Federation during the studied period was unstable (Fig. 8): in 2022, a sharp decrease in mortality rate is observed compared to 2021 (up to -14.09%); and already in 2023, compared to 2022, there was a significant increase in mortality rate in this group of animals.²³ The rate of changing reindeer population is slower and more predictable. It should be noted that the proportion of reindeer mortality relative to the total livestock population is significant: for example, over the years studied, it reached 19.03% in 2019 and

equalled to 14.93% in 2023²⁴. The “reindeer” group has a small share in the total population of all agricultural animals, therefore, an increase of mortality in this group could lead to the reduction of the reproduction capacity of the reindeer herd.

In the “camels” group (Fig. 9), significant fluctuations in the rate of changing mortality are observed, which does not correspond to the directions in which changing of camel population was going in most of the studied years^{25,26}.

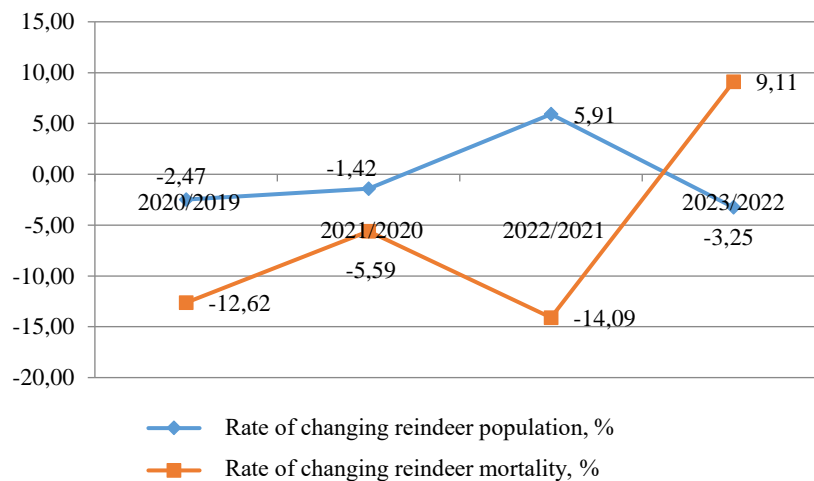

Fig. 8. Rates of changing the reindeer population and mortality in the agricultural enterprises of the Russian Federation in 2019–2023

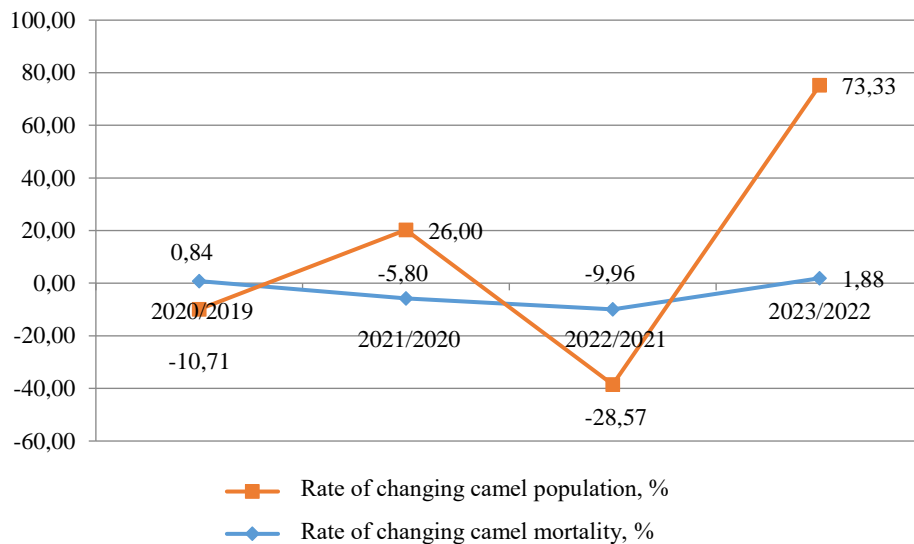

Fig. 9. Rates of changing the camel population and mortality in the agricultural enterprises of the Russian Federation in 2019–2023

²³ State of Livestock Farming. Bulletin for 2019–2023. Federal State Statistics Service. URL: <https://rosstat.gov.ru/compendium/document/13277> (accessed: 12.02.2024)

²⁴ Livestock Population in the Farms of All Categories. Bulletin for 2019–2023. Federal State Statistics Service. URL: <https://rosstat.gov.ru/compendium/document/13277> (accessed: 12.02.2024)

²⁵ Ibid.

²⁶ State of Livestock Farming. Bulletin for 2019–2023. Federal State Statistics Service. URL: <https://rosstat.gov.ru/compendium/document/13277> (accessed: 12.02.2024)

Key Factors Affecting the Increase of Livestock Mortality. The authors have identified the factors affecting animal mortality in the agricultural enterprises of the Russian Federation and the corresponding causes (Table 3).

The analysis of the factors makes it possible to summarise and identify the problems that underly these situations. Firstly, meat and dairy production often proves to be unprofitable for various reasons leading to reduction of investments in this subsector and, subsequently, to reduction

of milking and breeding herds. On the other hand, the resulting financial problems can lead to mass livestock mortality, as occurred in the poultry industry in July 2025: some farms were unable to maintain operations due to financial debts, which had led to the death of birds. The hidden costs resulting from animal mortality must also be taken into account: disposal costs, reduced production, deterioration of milk and meat quality, and the spread of infections.

Table 3

Factors affecting animal mortality in the agricultural enterprises of the Russian Federation

Causes	Specifics of influence
Environmental factors	
Natural disasters	Are often seasonal (floods, fires), therefore the time of their occurrence can be forecasted; in most cases, develop gradually, which gives time for undertaking measures to protect animals.
Dangerous animal diseases	Can be highly contagious and rapidly spreading, thus, require prompt veterinary care and early vaccination; in case of severe disease outbreaks, governments issue the Resolutions on the mass culling of animals potentially affected by the disease.
Technical and organisational factors	
Feed shortage (feed availability level for grazing animals)	Insufficient and unbalanced feeding leads to illnesses and problems in development of fetus in pregnant animals; feed shortage and feed-related cost saving lead to animal underweight, which reduces the yield of end livestock products and, consequently, the profit of agricultural enterprises.
Unsatisfactory condition of agricultural premises and equipment	Unsatisfactory zoohygienic conditions lead to deterioration of animal health and untimely death of young animals.
Organisational and human factors	
Insufficient level of qualification and discipline of the employees of agricultural enterprises	Noncompliance with animal feeding technologies, established requirements for the microclimate of livestock farming buildings, and the absence of on-duty agricultural specialists lead to an increase in animal morbidity and mortality.
Belated veterinary care and insufficient prophylaxis	The influence of this factor is possible in the event of discipline violations by the personnel of agricultural enterprises and noncompliance with the animal care regulations, the absence or violation of vaccination schedules.
Poor quality veterinary care	Insufficient qualification of a veterinarian; negligent attitude towards animals at the veterinary clinics; insufficient supply of necessary medications; use of low-quality or counterfeit medications; insufficient equipment in the veterinary clinics, including diagnostic equipment; inefficient organisation of work in the veterinary clinics [2].

Secondly, a neglectful attitude toward livestock welfare and pasture quality is currently observed, which, of course, reduces livestock productivity and increases uncontrolled disease incidence. Despite the measures taken, the epizootic situation in Russia remains tense. In early 2025, Federal Service for Veterinary and Phytosanitary Surveillance (Rosselkhozadzor) reported new cases of rabies and bovine leukemia.²⁷ The incidence of anthrax in 2025–2026 is expected to depend on the scale of vaccination and monitoring.

Thirdly, weakening of state regulation of these processes at both the federal, regional, and local levels, as well as the lack of transparent and efficient state policy, hinders the development of livestock farming sector and does not foster solution of the existing problems.

Discussion and Conclusion. Tracking the causes and trends of livestock mortality at the local and national levels is essential for planning, monitoring, and developing programs aimed at reducing mortality in agricultural animals. The study revealed a persistent negative trend developed in the Russian Federation over the period of 2019–2023, characterized by mortality growth rates exceeding population growth rates in most animal species, high volatility in mortality numbers, and the presence of critical aspects in pig and reindeer farming.

Particular attention should be paid to the decline in cattle population (including cows), one of the most significant and numerous groups, as well as to decline in the popula-

²⁷ Data as of April 7, 2025, on the Epizootic Situation in the Russian Federation. Federal Service for Veterinary and Phytosanitary Surveillance (Rosselkhozadzor). URL: <https://fsvps.gov.ru/files/informacija-ot-7-aprelja-2025-goda-po-jepizooticheskoi-situacii-v-rf/> (accessed: 14.02.2026)

tions of horses, reindeer, sheep, and goats. Although currently the proportion of mortality does not exceed 2% (in camels, horses, and cows), which is considered acceptable, it should still be kept under control and measures developed to prevent livestock mortality growth in the future. In the “sheep and goat” group, the proportion of mortality to the total population is approaching 4% and has the trend for rising. The growth of the mortality proportion in camels in 2023 is also a concern: management of the agricultural enterprises should investigate the causes underlying this situation and take measures to prevent further increase of this indicator.

High livestock mortality level poses a threat not only due to direct economic losses but also due to reducing the herd reproduction potential. This is particularly valid for reindeer mortality, which reached 19.0%, and even with a decline to 14.9% in 2023, the situation remains tense. A critical situation has also developed in pig farming, where the proportion of mortality relative to population increased from 32.2% in 2019 to 43.1% in 2023. It is recommended to develop the state programs aimed at reducing pig mortality, and strictly control the compliance with the disciplinary and technological requirements for pig farming in the agricultural enterprises, as well as to develop the preventive measures to reduce animal mortality [3, 4].

Table 4

Measures to reduce socio-economic damage from livestock mortality

Measure	Essence
Planning the actions to follow in the event of arising a livestock mortality causing situation	Knowing the main causes of livestock mortality makes it necessary to develop an action plan in the face of a threat of adverse events. This will allow the staff of agricultural enterprises to rationally assess the severity of the situation and the scale of potential losses and follow a clear plan of actions for preventing the situation or mitigating its negative impact. This measure is crucial in combating such causes of livestock mortality as natural disasters and dangerous diseases.
Livestock insurance	It is an efficient financial tool that protects agricultural producers in the event of emergency situations resulting in mass livestock mortality, as well as reduces damage from other negative factors. However, livestock insurance programs must be elaborated at the state level [5, 6].
Examining and testing animals throughout transportation and inclusion into the food chain	Constant monitoring of animal health will help promptly identify deviations and take measures to stabilize or isolate sick animals. Implementation of this measure will mitigate the influence of the factors increasing livestock mortality.
State support of agricultural enterprises in case of significant losses	Elimination of consequences of the natural disasters and combating especially dangerous animal diseases will require state support, since the scale of socio-economic damage may be so significant that the agricultural enterprises will not be able to solve the arising problems themselves to resume normal functioning [7].
Training and continuous professional development of employees of agricultural enterprises	Understanding the specifics of livestock management and proper technical and ethical handling of animals is crucial for increasing their productivity: improved keeping and care conditions reduce stress in animals, thus, lead to greater weight gain and improved quality of meat, milk, and other livestock products; such attitude reduces animals' losses caused by accidents, negligence, and staff ignorance. Furthermore, the introduction of internships in veterinary medicine opens up new opportunities for improving the quality of diagnostics: the specialty of “veterinary pathologist” is introduced, which improves postmortem examination of animals, allowing for more accurate determination of the true causes of mortality. Accurate diagnostics, in turn, provides the basis for the development of efficient preventive measures and targeted reduction of livestock mortality [8].
Expansion and disclosure of statistical data on animal mortality and its causes with respect to time period and location	Sufficient statistical data will enable the analysis of the causes of agricultural animal mortality, provision of a reliable and adequate assessment, and direction of resources for solving the identified theoretical and applied problems faced by modern livestock farming. This will increase awareness among the employees of the agricultural enterprises and enable them to make more efficient decisions.
Sensitizing scientific research in the fields of livestock farming, veterinary medicine, and economics	The availability of targeted scientific studies will enable the development and implementation of more efficient methods of combating livestock mortality, depending on the influencing factor.

Thus, in the studied period, across all groups of studied agricultural animals, significant fluctuations in the rate and direction of changing the mortality were observed, which indicates uncontrollability of this process and the lack of systemic management of this process in the agricultural enterprises. Uncontrollable livestock mortality can cause a cascade effect, with losses in agricultural industry entailing increased losses in related and dependent sectors of the country's economy. The state must not simply initiate some actions, but rather formulate a clear action plan, propose the tools and appoint the responsible bodies to prevent the catastrophic consequences of the uncontrollable processes in this area. To overcome these challenges, including achievement of import independence in technologies and means of production, as well as overcoming deficit of human recourses, the national project "Technological Support for Food Security" is being implemented since this year. It is stipulated that by 2030, Russia should provide

72% of its needs in improved breeding stock of dairy cattle and 10% — in improved breeding stock of poultry.

To complement the initiatives mentioned, we propose a set of practical measures (Table 3), including planning the actions in the face of mortality threat, developing the livestock insurance system, strengthening the state support in case of significant losses, improving the qualifications of workers, expanding and detailing statistical record on mortality with spatial and time reference, as well as intensifying scientific research in the field of veterinary medicine and livestock farming economics.

Consistent and ongoing implementation of these measures will ensure control over livestock mortality in agricultural enterprises, improve the predictability of livestock population dynamics, and eventually reduce the socio-economic damage to the state by strengthening the food security of the Russian Federation.

References

1. Zhuchayev KV, Kochneva ML, Borisenko EA. Welfare of Productive Animals (Review) Welfare of Productive Animals (Review). *Sel'skokhozyaistvennaya biologiya (Agricultural Biology)*. 2024;59(6):1025–1038. (In Russ.) <https://doi.org/10.15389/agrobiology.2024.6.1025rus>
2. Lapshova OA, Kramlikh OYu, Kiyashchenko LT, Sapozhnikova SM. Improving the Activities of Veterinary Services in Order to Ensure Food Security at the Regional Level. *Economic Systems*. 2022;15(3(58)):183–196. (In Russ.) <https://doi.org/10.29030/2309-2076-2022-15-3-183-196>
3. Kiselev VA, Akimova SV, Marchenko LA. The Current State and Main Trends in the Development of Dairy Farming. *Vestnik Akademii znaniy (Bulletin of the Academy of Knowledge)*. 2024;(6(65)):413–418. (In Russ.).
4. Krinichnaya EP. Current State and Problems of the Livestock Industry in the Southern Federal District. *Bulletin of Agrarian Science*. 2025;(2(113)):72–83. (In Russ.).
5. Maximova SYu, Murzageldieva EB, Orujeva LSh. Prospects for the Development of Agricultural Animal Insurance Use. *Regionalnye problemy preobrazovaniya ehkonomiki (Regional Problems of Economic Transformation)*. 2021;(4(126)): 47–55.
6. Pai J, Ravishanker N. Livestock Mortality Catastrophe Insurance Using Fatal Shock Process. *Insurance: Mathematics and Economics*. 2020;90:58–65.
7. Valeeva AV. Instruments for State Financial Support for Agriculture and Increasing Their Efficiency. *International Journal of Humanities and Natural Sciences*. 2023;(5–2(80)):142–144. (In Russ.).
8. Volkov IK, Potapenko IO, Ermakov AM. Internship and Professional Titles in Veterinary Medicine: Legal Risks and Limits of Acceptable Qualification Declaration. *Legal Regulation in Veterinary Medicine*. 2026;1:47–53. (In Russ.). <https://doi.org/10.52419/issn2782-6252.2026.1.47>

About the Authors:

Elena O. Mirgorodskaya, Dr.Sci. (Economics), Professor, Head of the State and Municipal Management Department, Don State Technical University (1, Gagarin Sq., Rostov-on-Don, 344003, Russian Federation), [SPIN-код](#), [ORCID](#), [Researcher ID](#), [Scopus ID](#), emirgorod@mail.ru

Yulia L. Stepanova, Cand.Sci.(Economics), Associate Professor of the State and Municipal Management Department, Don State Technical University (1, Gagarin Sq., Rostov-on-Don, 344003, Russian Federation), [SPIN-код](#), [ORCID](#), [Researcher ID](#), [Scopus ID](#), batcukova@mail.ru

Igor O. Potapenko, Applicant for a Scientific Degree, Educational and Methodological Work Specialist of the Living Systems Institute, Don State Technical University (1, Gagarin Sq., Rostov-on-Don, 344003, Russian Federation), [SPIN-код](#), [ORCID](#), potapenko@gmail.com

Alexey M. Ermakov, Dr.Sci. (Biology), Professor, Director of the Living Systems Institute, Don State Technical University (1, Gagarin Sq., Rostov-on-Don, 344003, Russian Federation), [SPIN-код](#), [ORCID](#), [Researcher ID](#), [Scopus ID](#), amermakov@yandex.ru

Claimed Contributorship:

ЕО Mirgorodskaya: scientific supervision, development of methodology, analysis of the research results.

YL Stepanova: data processing, preparing the text, formulating the Discussion and Conclusion section.

Ю Potapenko: writing the manuscript, formulating the conclusions.

АМ Ermakov: scientific supervision, formulating the main concept, formulating the Discussion and Conclusion section.

Conflict of Interest Statement: the authors declare no conflict of interest.

All authors have read and approved the final manuscript.

Об авторах:

Елена Олеговна Миргородская, доктор экономических наук, профессор, заведующая кафедрой «Государственное и муниципальное управление» Донского государственного технического университета (344003, Российская Федерация, г. Ростов-на-Дону, пл. Гагарина, д. 1), [SPIN-код](#), [ORCID](#), [Researcher ID](#), [Scopus ID](#), emirgorod@mail.ru

Юлия Леонидовна Степанова, кандидат экономических наук, доцент кафедры «Государственное и муниципальное управление» Донского государственного технического университета (344003, Российская Федерация, г. Ростов-на-Дону, пл. Гагарина, д. 1), [SPIN-код](#), [ORCID](#), [Researcher ID](#), [Scopus ID](#), batcukova@mail.ru

Игорь Олегович Потапенко, соискатель, специалист по учебно-методической работе Института живых систем Донского государственного технического университета (344003, Российская Федерация, г. Ростов-на-Дону, пл. Гагарина, д. 1), [SPIN-код](#), [ORCID](#), potapenko@gmail.com

Алексей Михайлович Ермаков, доктор биологических наук, профессор, директор Института живых систем Донского государственного технического университета (344003, Российская Федерация, г. Ростов-на-Дону, пл. Гагарина, д. 1), [SPIN-код](#), [ORCID](#), [Researcher ID](#), [Scopus ID](#), amermakov@yandex.ru

Заявленный вклад авторов:

Е.О. Миргородская: научное руководство, разработка методологии, анализ результатов исследований.

Ю.Л. Степанова: обработка данных, подготовка текста, формирование обсуждений и выводов.

И.О. Потапенко: написание рукописи, формирование заключения.

А.М. Ермаков: научное руководство, формирование основной концепции, формирование обсуждений и выводов.

Конфликт интересов: авторы заявляют об отсутствии конфликта интересов.

Все авторы прочитали и одобрили окончательный вариант рукописи.

Received / Поступила в редакцию 14.02.2026

Reviewed / Поступила после рецензирования 10.03.2026

Accepted / Принята к публикации 13.03.2026